

DSX

SERVICE MANUAL

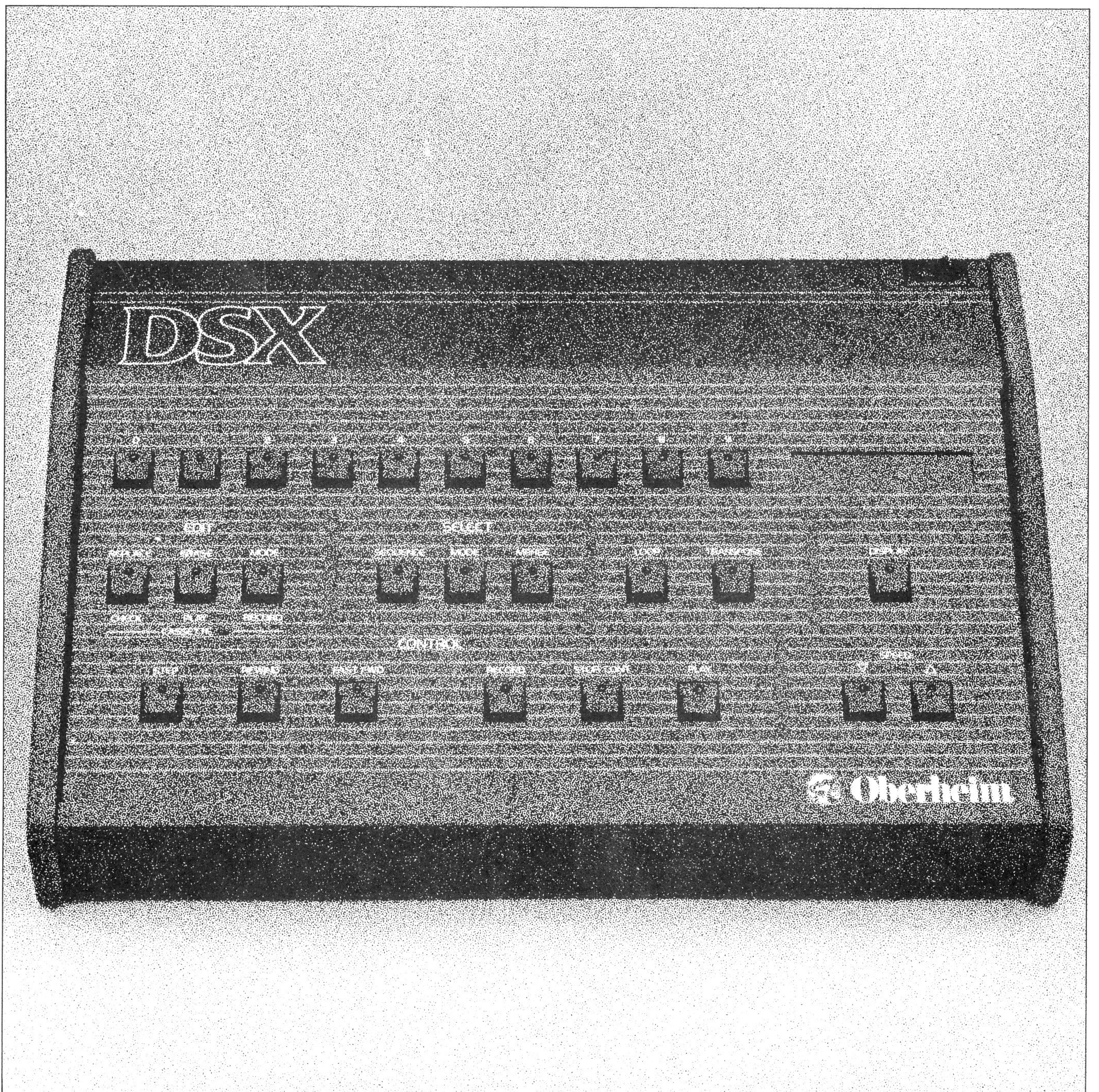

DSX
DIGITAL POLYPHONIC SEQUENCER

: SERVICE MANUAL :

FEBRUARY 1982

TABLE OF CONTENTS

TECHNICAL NOTES

- Improvements and Additions - February 1982
- Functional Test and Calibration
- Operation of Cassette Interface
- Operation of Sync-To-Tape Circuit
- Computer Interface Description
- DSX Software History - February 1982
- DSX Connectors
- Parts List

SCHEMATICS

- Processor Board (3 Sheets)
- Early Sync. Circuit
- Switch Board
- Rear Panel
- External Keyboard

PARTS LAYOUT DIAGRAMS

- Processor Board
- Switch Board

PRINTED CIRCUIT COMPOSITE DIAGRAMS

- Processor Board
- Switch Board

ENGINEERING CHANGE ORDERS (ECO's)

- ECO # 201
- ECO # 202
- EOC # 203

CORRECTION NOTICE (Business Reply Letter)

OBERHEIM ELECTRONICS, INC.
2250 So. Barrington Ave.
Los Angeles, CA 90064

IMPROVEMENTS AND ADDITIONS - FEBRUARY 1982

ECO #201: This change has been made to keep the battery back-up from failing. It changes diode D10 from a 1N4148 to a 1N4002.

ECO #202: This change allows for extra storage of program software by changing a 2716 EPROM to a 2732 EPROM. This modification requires 2 cuts, 3 jumpers, and the removal of one existing jumper on the back of the DSX control board. With the addition of the three new EPROMS the following software corrections have been made:

PROBLEM	CORRECTION
Cassette interface doesn't work	New software greatly improves the cassette interface while keeping it compatible with existing cassettes. Also, the display will now indicate when the leader tone has been recognized.
When transposing a sequence, the note played on the keyboard can be heard	New software silences the note being used to transpose a sequence.
When recording a CV, the voices in the OB-Xa play with it	New software keeps voices from playing keyboard while recording a CV.
When slaving the DSX to the DMX the DSX seems to fall behind	New software keeps track of all incoming clock pulses and keeps the DSX from falling behind.
To loop exactly in time with DMX, track 0 must be recorded	New software allows all tracks to store a correct end of sequence.
The speed seems to change too slowly while playing	New software allows speed to be changed faster.
When memory is empty, pressing display while in record ready causes the display to read 5535 NOTES FREE	New software corrects this display error.
When a sequence is stopped in the middle, the CVs sometimes output a short note	New software corrects this problem.
If an external Gate is on when a sequence is started, it will stay on until that CV is used	New software corrects this problem.

ECO #202 software also includes the following new features:

1. Currently, only one CV can be recorded on an individual track, causing the need for 8 tracks in order to utilize all 8 CV's. Now, using Edit Mode 5, a track that has been recorded on OB-Xa voices can be transferred to the external CV outputs, and vice versa. This means that if a track was recorded with voices 1 through 6 assigned to it, Edit Mode 5 would assign it to CV's 1-6. Selecting Edit Mode 5 again for this track would assign it back to voices 1-6.
2. The Play/Stop Footswitch has two added functions. The first allows the record mode to be started without a count down, and the second allows the record mode to be stopped and immediately to begin playing back what was just recorded.

When the DSX is in Record Ready (Record light flashing) and the footswitch is pressed, the DSX will go immediately into Record without counting down. When the DSX is in Record and the footswitch is pressed, the DSX will immediately play back what was just recorded.
3. The new software now allows the DSX to be remotely started and stopped by the DMX or another DSX. The DSX will automatically sense an incoming clock pulse and immediately jump into play. If 125 milliseconds pass without a clock pulse, the DSX will automatically go into stop. These new features can also cause the following undesirable situations. If the STOP button on the DSX is pressed while its master is still playing, it will jump back into play until the master is stopped. Also, if LOOP is not on while the DSX is slaving to an external clock, the DSX will loop back into play when the sequence is over anyway and possibly fall slightly behind, since it is possible for it to miss a clock while it was in STOP. All of these functions can be defeated by not grounding the RING of the EXT CLOCK IN jack.
4. Sequences can now be changed while a sequence is playing. If a number is pressed while a sequence is playing, that sequence will play when the current sequence is finished, regardless of whether or not LOOP is on. If play is pressed after a new sequence is pressed, the new sequence will begin playing immediately. The sequence currently being played will always be displayed on the 0-9 LED's. When MERGE is on, this function is turned off.
5. Playtracks can now be changed while a sequence is playing. If SEQUENCE is pressed while a sequence is playing, the display will read SELECT PLAY TRKS and the 0-9 LED's will display the currently selected play tracks. To turn a track on or off, just push its associated number. The tracks turn on only at the beginning of a note and turn off only at the end of a note, so as not to cause abrupt changes in the music while playing.
6. The external Control Voltages and Gates can now be disabled when not in the PLAY mode. On the old software, anytime the DSX was not playing, it would output whatever the voices in the OB-Xa were playing to the CV's and Gates. With the new software, this

feature can now be defeated. If while holding TRANSPOSE the DISPLAY button is pressed, the CV outputs will be turned off or on, depending on its previous state. The display will read either "CV OUTPUTS ON" or "CV OUTPUTS OFF". This function will not affect the CV's recorded into sequences. It will only affect whether or not the notes on the OB-Xa keyboard will be outputted to the CV's and Gates.

7. The new software is now able to recognize whether a DSX is 3000 notes or 6000 notes without having to change any EPROMS. This recognition only occurs when memory is empty.
8. On sequencers without the memory expansion the maximum amount of notes that can be recorded is now 3133, rather than the previous limit of 3120. With the memory expansion the limit remains 6000 notes.

ECD #203: This change reduces the amount of clock noise present when a DSX is slaved off of a DMX. Resistors 122 and 123 must be changed from 470 Ohms to 1k Ohms. Resistor 42 must be changed from 4.7k Ohms to 10k Ohms.

FUNCTIONAL TEST AND CALIBRATION

1. Visually inspect internal wiring to transformer, back panel, and front panel. Check that all IC's are inserted correctly with all legs properly in their sockets. Turn on the power and check all voltages to the following tolerances: +12V & -12V supplies (+/- 600 mV), +5MEM (4.5 to 5V), and +5 (calibrate T3 to +5V, +/- 50 mV). Turn power off.
2. Connect multipin ribbon cable to synthesizer and DSX. Turn synthesizer power on. Turn CASSETTE ENABLE switch off.
3. Turn DSX power on. The display should read * OBERHEIM DSX *. If so continue to step 4. If not, the following things should be checked:
 - a. If display reads CONNECT SYNTH, check that the ribbon cable is securely connected. Check interface circuitry of DSX and the synthesizer.
 - b. Make sure all three EPROMS (ICs 63, 75, & 76 in the DSX) are inserted correctly.
 - c. Check for a 2.46MHz clock at pin 6 of the Z-80 (IC 64).
 - d. Check pin 26 of the Z-80 (RESET*) for a positive transition upon power on.
 - e. Check 6116 RAM in socket #55.
 - f. Check decoding to EPROM and RAM; I.C.s 53, 54, 67, 50, 44, 45, 43, 28, 29.
4. Connect a cassette player to the Cassette Interface of the DSX and turn the Cassette Enable switch on. The display should now read CASSETTE MODE and the Cassette LED should be on.
5. Load the cassette labeled DSX DIAGNOSTIC CASSETTE into the DSX as described in the DSX owner's manual.
6. After receiving the DATA COMPLETED message, turn the Cassette Enable switch off and stop the tape recorder. The display should now read DSX TEST PROGRAM. The following tests exist in this program. They are accessed using the 0 thru 9 switches. All other switches, including the Cassette Enable switch, should respond when pressed by lighting up, indicating that the switch is being scanned properly. All eight gate DIP switches located inside at the lower left hand side of the switch board should also be checked accordingly: DIP switch open, GATE out 0V; DIP switch closed, GATE out +12V, +/- 1V.

- TEST 0: This routine tests all of RAM located in sockets 56-62, 68-74. It will display the number of the ram it is currently testing on the alpha-numeric display. If the test is successful, it will display the message "3000 NOTES O.K." if it is a 3000 note sequencer, and "6000 NOTES O.K." if it is a 6000 note sequencer. If there are any errors, the IC number with the error will be displayed, e.g. "ERROR MEMORY 58". To exit this test, press the STOP button.
- TEST 1: This test checks the real time clock interrupt. The display will read "INTERRUPT TEST" for approximately .6 seconds, and if the interrupt is functioning, will then display "INTERRUPT CHECKED". Otherwise it will display "INTERRUPT ERROR". To exit this test, press the STOP button.
- TEST 2: This is the computer interface test. The DSX must be connected to a synthesizer for this test to work, otherwise the display will read "CONNECT SYNTH" until a synthesizer is connected or STOP is pressed. If a synthesizer is connected, the display will read "INTERFACE TEST" and will step the program advance of the synthesizer. STOP must be pressed to exit this test.
- TEST 3: The display will read "ALL LEDS ARE ON" and all leds should be lit. To exit this test, press STOP.
- TEST 4: This test checks all digits of the alpha-numeric display. The display will read "A/N DISPLAY TEST" for approx. .5 seconds, and then proceed to display a condensed ASCII set on all 16 displays, stepping approx. 1 character per .1 seconds. To exit this test, press STOP.
- TEST 5: This test displays "DAC TEST 0 VOLTS" and will output 0 volts to all 8 CVs on the rear panel. All 8 gates should be high (+12V + or - 1V). The offset of the DAC should be calibrated now so that the output voltage of CV 1 is 0.00 volts using the trimmer located next to IC 21 (T1). Check that the other 7 CVs don't vary more than + or -10mv from 0 volts. The output voltage of the DAC can be incremented in 1 volt steps up to 9 volts by pressing the SPEED UP button. Press the SPEED UP button 5 times so that the display reads "DAC TEST 5 VOLTS". Adjust the V/OCT 20-turn trimmer (T2) located to the right of the offset trimmer until the output of CV 1 equals 5.00 volts. Continue pressing the SPEED UP button until the display reads DAC TEST 9 VOLTS and make sure the voltage is 9 volts + or - 15 mv. Using the SPEED DOWN button, decrement the output voltage 1 volt at a time, checking the linearity of the DAC as the voltage drops. Check the other 7 CVs using the SPEED UP and SPEED DOWN switches to make sure they go from 0V to 9V. To exit this mode, press STOP.

TEST 6: This is the "METRONOME TEST". The speaker should click approx. once every .3 seconds. The metronome will not click if the CASSETTE ENABLE switch is on or if the speaker switch is off. To exit this test, press STOP.

TEST 7: "KBD TST NOTE ". This test does nothing unless an external keyboard is plugged in. If an external keyboard is plugged in, the display will show the letter name of the lowest key being pressed on the keyboard. To exit, press STOP.

TEST 8: "NO TEST EIGHT". Not functioning at this time. Exit with STOP.

TEST 9: "NO TEST NINE". Not functioning. Exit with STOP.

The cassette interface allows data stored in the unit's memory to be preserved on audio cassette tape. The circuitry consists of an Output-to-Tape section and an Input-from-Tape section.

OUTPUT-TO-TAPE SECTION

For each "1" which the microprocessor finds in memory and sends to the Cassette Interface Output-to-Tape section, the circuitry will generate one period of a 4800 Hz. sine wave, and for each "0" one period of a 2400 Hz. sine wave. This is accomplished as follows:

1. U78 divides the system clock in order to produce a 38.4 KHz. clock on pin 10. The differentiator consisting of C41 and R59 takes this signal and produces a narrow pulse which is applied to U42-2.
2. U48-2 is the 38.4 KHz. clock divided by two. It is applied to U42-5.
3. CDATO is the data bit stream supplied by the microprocessor and is applied to U42-6.
4. The result of this logic is U42-3 which goes to U40-14. This signal is a pulse train with pulses occurring at a 19.2 KHz. rate if CDATO is a "0" and at 38.4 KHz. if CDATO is a "1".
5. U40 is a Johnson counter (shift register-counter) which is combined with three resistors in a simple D-to-A configuration to both divide the incoming pulse train by 8, and produce a rough approximation of a sine wave at either a 2400 Hz. rate (CDATO = "0"), or a 4800 Hz. rate (CDATO = "1").
6. The signal CASS2 (U40-4) informs the microprocessor that the next data bit can be transmitted on CDATO.
7. Q9 and the associated capacitors and resistors comprise a filter which smooths the rough sine wave output. This final signal is then sent to the recorder.

The general format for data recorded on tape is:

- LEADER (6 seconds at 2400 Hz.)
- SYNCHRONIZATION BYTE (0101 0101)
- VERSION NUMBER
- 16 BYTES OF ZEROS
- SYNCHRONIZATION BYTE (0101 0101)
- LENGTH OF TRANSMISSION TO FOLLOW
- DATA (Pointers)
- CHECKSUM
- 17 BYTES OF ZEROS

- SYNCHRONIZATION BYTE (0101 0101)
- LENGTH OF TRANSMISSION TO FOLLOW
- DATA (Sequences)
- CHECKSUM
- TRAILER (2400 Hz. Tone)

INPUT-FROM-TAPE SECTION

The purpose of the Input-from-Tape section is to notify the microprocessor that a signal is being received from the recorder and to convert each period of an incoming 2400 Hz. signal into a "0" and each period of an incoming 4800 Hz. signal into a "1". This is accomplished as follows:

1. The circuitry surrounding U80-7 is a signal detector which produces a logic signal (CASS1) to inform the microprocessor that a signal of sufficient level is being received from the recorder. A 4 second delay is provided by R101 and C45, and two gates in U42 provide a Schmitt trigger to convert the delayed signal to logic levels. Transistor Q7 resets C45 during the initialization period.
2. U80-1 is a high gain amplifier which converts the incoming audio signal into a logic signal (CASS0) for use by the microprocessor.
3. The microprocessor, by interrogating CASS0, can measure the length of each incoming half-period. Depending upon the length, it stores into memory either a "0" or a "1". Since only the positive half-period is reliable, A NON SIGNAL INVERTING CASSETTE RECORDER MUST BE USED. That is, the input and output signals of the recorder must be in phase.
4. At the end of the read process, an error message will be displayed if the checksum which is calculated while the data is being read in does not equal the checksum recorded on tape.

OPERATION OF SYNC-TO-TAPE CIRCUIT

The Sync-to-tape circuit provides the necessary hardware to allow a signal on a tape recorder to control the speed of operation of the unit. Synchronization information is communicated by a 2400/4800 Hz tone. The actual useful information is the number of times per second that the tone changes frequency between 2400 and 4800 Hz. The frequency CHANGES can occur anywhere between 40 Hz and 400 Hz. For example, a typical section of the detected signal may look like:

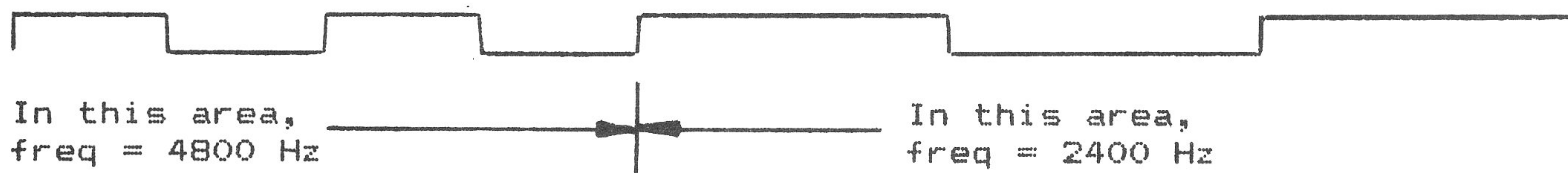

This is a section showing a CHANGE and the changes can occur anywhere from 40 times/second up to 400 times/second.

The detection circuit works as described below.

1. The input audio waveform is first clipped by U80 and then the edges are detected by U26 and U29, generating a PULSE:

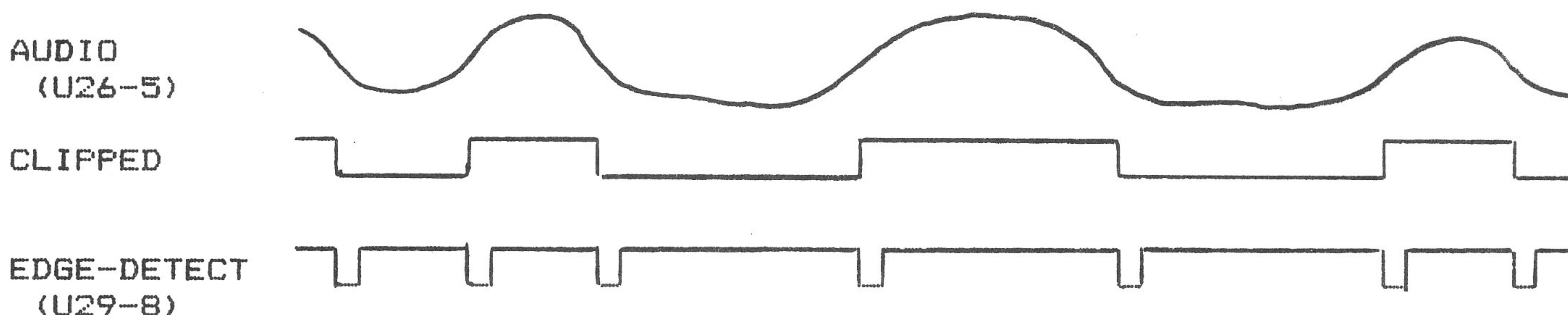

2. The pulse generated by each zero-crossing of the waveform is about 6 usec. wide and the pulses are either 1/4800 of a second or 1/2400 of a second apart.
3. The heart of the detection circuit is an 8-bit binary counter, U27, which works in conjunction with two flip-flops, U25. When a PULSE occurs, the down counter is loaded with a count of 47. This counter is counted down by a 154 KHz (6.51 usec. period) clock.
4. With the counter preset to 47, it takes 48 clock periods to count it down to zero. Since the clocks occur every 6.51 usec. it takes 312 usec. for the counter to reach zero.
5. If the input frequency is 2400 Hz (417 usec. between PULSE's), the counter reaches zero after 312 usec. When it does, the counter is stopped until the next PULSE and a flip-flop is set. This flip-flop, U25, will stay set as long as the input frequency is 2400 Hz.

6. If the input frequency is 4800 Hz (208 usec. between PULSE's), the counter never reaches zero and is continually preset by PULSE. In this case, the above mentioned flip-flop, U25, is reset and stays reset.
7. The turning on and off of this flip-flop represents a change from 2400 Hz to 4800 Hz. A second edge detector circuit, U41, U54, and U25, produces a pulse when this change occurs and this pulse drives the CPU interrupt logic.

COMPUTER INTERFACE DESCRIPTION

When an OB-Xa (SX/X) is ready to transmit data to the COMPUTER INTERFACE, the HINT* line goes low (active). The OB-Xa then waits approximately 100 microseconds for a BUSRQ*. During this time the HRV* line must go low in order to read in the vector placed on the first five data lines, followed by BUSRQ* going low (within the 100 microseconds). The three most significant bits must be masked off the vector since they contain random data. The five bits of data are used to determine at what point in the program the OB-Xa is in. After the 100 microseconds, (plus the time that BUSRQ* was held low), the OB-Xa will reset the HINT* line, reset the five data lines, and read in COMFLG into the A register, to possibly be used in the OB-Xa.

HINT*	D0	D1	D2	D3	D4	LOCATION IN PROGRAM
0	0	0	0	0	0	KEYBOARD ROUTINE, JUST AFTER SCANNING KEYBOARD
0	0	1	1	0	0	BEGINNING OF PROGRAMMER ROUTINE
0	0	1	1	1	0	BEGINNING OF MAIN SCAN JUST AFTER SCANNING THE SWITCHES (OB-Xa ONLY)

If during the keyboard interrupt, COMFLG is made non-zero, the rest of the keyboard routine is skipped. This allows the insertion of notes directly to specific voices (called NVAL, located in RAM at 4010 to 4017 hex) while ignoring any notes being played on the keyboard. If during the programmer interrupt COMFLG is made non-zero, the OB-(S)X(a) will assume a program change has been made (by altering OLDPGM, located at RAM location 402E hex), and act accordingly. COMFLG has no affect on the main scan interrupt.

OB-Xa RAM LOCATIONS

ADDRESS	NAME	DESCRIPTION
4010-4017	NVAL	NOTES PLAYED BY THE 8 VOICES
4001-4009	BUFF	KEYS BEING DEPRESSED ON THE KEYBOARD
402E	OLDPGM	CURRENT PROGRAM
40AA	COMCAL	COMPUTER INTERFACE FLAG
40E0-40EF	SW	STORAGE LOCATIONS FOR FRONT PANEL SWITCH POSITIONS (not on OB-X or OB-SX)

NVAL: These 8 locations contain the data currently being played by the voices in the OB-Xa. NVAL contains information for voice 1, NVAL+1 contains information for voice 2, etc. The information is stored as follows: Bit 0-5 contain the note number (0 through 63), bit 6 is the HOLD bit and bit 7 is the GATE bit. The HOLD bit, when set, causes a voice to remain at its current pitch even if the keys are released. The GATE bit when set, sends a gate voltage to both envelope generators of the selected voice.

BUFF: These 9 locations contain data relating to the keys currently being played on the keyboard. The data can represent a key (0-63H), or it can represent no key being depressed at that location (FFH). BUFF+9 contains the lowest note being played on the keyboard, and BUFF is the highest. The OB-Xa uses this data during the keyboard routine to determine what notes to output to the voices.

OLDFGM: This location contains the program number currently being used in the instrument. In the OB-X, it can be 0-1FH; in the OB-SX, 0-17H; in the OB-Xa, 0-1FH; in the OB-Xa/120, 0-77H. These numbers relate to the selected programs in the following manner: The three least significant bits represent the PROGRAM number 1-8, bits 3 & 4 represent the GROUP A-D (on the OB-Xa/120 there are 15 possible groups, represented with bits 3 through 6).

COMCAL: This location is used to tell the OB-Xa to respond in a predetermined manner to the information given to it from the computer interface.

SW: These 16 locations contain a bit for each switch and each key on the keyboard on the OB-Xa only. That data is arranged as follows:

ADDRESS	D0	D1	D2	D3	D4	D5	D6	D7
40E0	C0	C#0	D0	D#0	E0	F0	F#0	G0
40E1	G#0	A0	A#0	B0	C1	C#1	D1	D#1
40E2	E1	F1	F#1	G1	G#1	A1	A#1	B1
40E3	C2	C#2	D2	D#2	E2	F2	F#2	G2
40E4	G#2	A2	A#2	B2	C3	C#3	D3	D#3
40E5	E3	F3	F#3	G3	G#3	A3	A#3	B3
40E6	C4	C#4	D4	D#4	E4	F4	F#4	G4
40E7	G#4	A4	A#4	B4	C5	--	--	--
40E8	PROG1	PROG2	PROG3	PROG4	PROG5	PROG6	PROG7	PROG8
40E9	GRP A	GRP B	GRP C	GRP D	HOLD	CHORD	SUSTFS	PRGADV
40EA	--	--	--	UNISON	LFOSIN	LFOSQR	LFOS/H	FMOSC1
40EB	FMOSC2	FMFILT	FMOSC1	FMOSC2	OSC1SW	OSC1SQ	OSC2SW	OSC2SQ
40EC	OSC1FL	TRACK	OSC2HF	OSC2FL	NOISE	4-POLE	SYNC	F-ENV
40ED	--	LOWER	UPPER	SPLIT	--	TEST1	TEST2	AUTO
40EE	MANUAL	WRITE	DOUBLE	--	RGATE*	CASSET	CDATI*	DREQ*
40EF	VOICE1	VOICE2	VOICE3	VOICE4	VOICES5	VOICE6	VOICE7	VOICE8

Here is an description of how communication occurs between an OB-Xa and a DSX when connected together through the computer interface.

The DSX, while in play, keeps track of the current "time of day" with its real time clock and decides whether or not it is time to play a note. When it is time to play a note, the DSX stores that note into a particular place in its memory. When it is time to stop playing that note, it takes the note out of that place in memory. In the mean time, if the OB-Xa has reached one of its three routines in which it calls the Computer Interface, it will place a vector onto the first 5 data lines and set the HINT* line low. This signal causes a non-maskable interrupt to occur in the Z80 of the DSX, forcing it to stop what it is doing and immediately execute a specific part of its program. This program will read in the vector and then set BUSRQ* low. The Z80 in the OB-Xa will send a BUSAK* signal and then stop everything until the BUSRQ* line returns to its normally high state. The DSX will then determine, using the vector, whether or not any communication is necessary between the DSX and the OB-Xa. If the vector indicated that the OB-Xa was in its keyboard routine and the DSX had a note to play, the DSX would then output the note into the appropriate memory location of the OB-Xa and make the memory location COMFLG non-zero. After this the DSX would return BUSRQ* to a high state, allowing the OB-Xa to resume its program. The OB-Xa would then output the note to the proper voice.

To determine the version number of the software in a DSX, press and hold the 3, 5, and 7 buttons. The display will show the version number while these buttons are held down.

"DSX 1.00 (C)1981"

Version 1.00 is the first release of software for 3000 note DSX's, and should be updated to version 2.00 by implementing ECO's 201, 202 and 203.

"DSX 1.01 (C)1981"

Version 1.01 is the first release of software for 6000 note DSX's and should be updated to version 2.00 by implementing ECO's 201, 202 and 203.

"DSX 2.00 (C)1982"

Version 2.00 is the second and most recent release of software (as of Feb. 1982) for 3000 and 6000 note DSX's, and includes all of the changes describe in "IMPROVEMENTS AND ADDITIONS - FEBRUARY 1982".

CONNECTOR A
CONTROL BOARD TO SWITCH BOARD

PIN	LABEL
A1	GND
A2	GND
A3	GND
A4	GND
A5	D0
A6	D1
A7	D2
A8	D3
A9	D4
A10	D5
A11	D6
A12	D7
A13	A0
A14	A1
A15	A2
A16	A3
A17	SWEN6*
A18	SWD6*
A19	SWD5*
A20	SWD7*
A21	SWEN5*
A22	N.C.
A23	LED1*
A24	IOR*
A25	N.C.
A26	WR*
A27	DISP*
A28	LED3*
A29	LED2*
A30	LED0*
A31	+5V
A32	+5V
A33	+5V
A34	+5V

CONNECTOR B
CONTROL BOARD TO SYNTHESIZER INTERFACE

PIN	LABEL
B1	HA11
B2	HA10
B3	HA9
B4	HA8
B5	HA7
B6	HA5
B7	HA3
B8	HA1
B9	HD0
B10	HD1
B11	HD2
B12	HD3
B13	HRV*
B14	BUSRQ*
B15	N.C.
B16	HINT*
B17	HWR*
B18	HMRQ*
B19	N.C.
B20	N.C.
B21	N.C.
B22	HRD*
B23	GND
B24	GND
B25	GND
B26	GND
B27	GND
B28	N.C.
B29	HD4
B30	HD5
B31	HD6
B32	HD7
B33	HA0
B34	HA2
B35	HA4
B36	HA6
B37	HA15
B38	HA14
B39	HA13
B40	HA12

CONNECTOR C
CONTROL BOARD TO REAR PANEL

PIN	LABEL
C1	CD6*
C2	SWEN6*
C3	KEY (N.C.)
C4	GND
C5	FR0T*
C6	OINT*
C7	OLOOP*
C8	CLICK
C9	EXTSW
C10	INTIN
C11	LOOPIN
C12	CASIN
C13	CASOUT

CONNECTOR D
CONTROL BOARD TO POWER TRANSISTOR

PIN	LABEL
D1	PT1
D2	KEY (N.C.)
D3	PT2
D4	PT3

CONNECTOR E
CONTROL BOARD TO POWER TRANSFORMER

PIN	LABEL
E1	AC1
E2	AC2
E3	KEY (N.C.)
E4	GND (CT)
E5	GND (CT)
E6	N.C.
E7	AC3
E8	AC4

QNTY	PART #	DESCRIPTION
		COMPLETE ASSY DSX SHIPPING
1	131002	LOUDSPEAKER 2 1/4" 8 OHM 1/4W
1	131005	MAG TAPE CASSETTE 2MIN DSX DAK EC-2
1	219018	AC REC 3COND PAN MT SCRFT EAC-301
1	241009	LENS RED NO. 60
1	281004	SCREW 6-32X3/8 PHIL 100 FLAT BL OX
28	281018	SCREW 6-32X5/16 PHIL PAN BLK OX
2	281029	SCREW 4-40X1/2 PHIL PAN CAD FLT
2	281033	SCREW 8-32X3/8 PHIL PAN BLK OX
4	281044	SCREW 6-32X1/4 PHIL PAN BLK OX
6	281050	SCREW 6-32X3/8 PHIL PAN BL OX
4	281054	SCREW 8-32X3/4 100 OVAL BL OX
2	281055	SCREW 8-32X3/8 100 OVAL PHIL BL OX
2	282003	NUT 3/8-32X1/2X.093 HEX NICKEL PLTE
39	282009	NUT 6-32 SMALL PAT W/LOCKWSHR KEPS
2	282010	NUT 4-40 W/LOCKWASHER KEPS CAD
2	282011	NUT 8-32 W/LOCKWASHER KEPS CAD
4	286006	SPACER 1/4X1/8X.140 ID NYLON
12	286022	SPACER 1/4X11/32X.140 RND AL
2	286503	WASHER 3/8 INT TOOTH LOCK STL CD
2	286506	WASHER #8FLAT .172IDX.375ODX.032 CD
4	286511	WASHER #8 CUP OR FINISHING BLK OX
2	286519	WASHER #8 INT TOOTH LOCK
1	287501	WASHER 1/4X1/2X1/32 THK FIB KFW/378
1	287503	WASHER .500 ODX.260 IDX.071X.031 SH
3	289010	SOLDR LUG #6 SCREW CLEAR BT 1414-6
4	289016	FILLER FOR #8 CUP WSHR NYL NW-15-8
1	289054	CABLE CLAMP SELF STICK 3/16 ID
4	289058	FOOT 3/4"SQX1/4 RBR SJ-5023BLK
1	478470	RESISTOR FXD 1/4W 2-5% 47 OHM
1	510211	SWITCH RK SPST RED LENS
1	515004	FUSE 1/2 AMP SLO-BLD 3AG 313500
1	515507	FUSE BLOCK 1 POLE 3AG SOLDER LUG
1	600011	LINE CORD 3CON 7.5FT GY EUROPEAN
24	608000	WIRE 20 19/32 BLK PVC U
1	711537	DSX STOP
1	711544	DMX/DSX END BELL SET WALNUT
1	711561	DMX/DSX HINGE 16 7/8 L
1	711565	DSX FRAME
1	711567	DSX FRONT PANEL
1	711572	DMX DSX AC SHIELD
1	711575	DSX CONNECTOR COVER
1	720063	PCB SUB-ASSY DSX PROCESSOR
1	720064	PCB SUB-ASSY DSX FOT
1	730105	MECH SUB-ASSY DSX TRANSFORMER
1	730106	MECH SUB-ASSY DSX REGULATOR
1	750148-0	CABLE SUB-ASSY DSX #01 MADE OUT
1	750149-1	CABLE SUB-ASSY DSX #2
1	750151	CABLE SUB-ASSY DSX #4
1	811502	DMX/DSX HINGE BLK ANODIZE

1	811568	DSX FRT PANEL TEXTURE SCREEN
1	811569	DSX FRAME PANEL BLK TEXTURE SCREEN
1	811580	DSX CONNECTOR COVER
1	811581	DSX STOP BLACK TEXTURE
1	920003	BAG POLY 18X24 2MIL DSX/DMX
1	921009	CARTON DMX/DSX 22X16X10 200# RSC
1	930021	PRCHD OUTSD LABOR DSX CABLES
1	940016	I. D. TAG DSX
1	942008	LABLE CAUTION VOLTAGE SETTING
1	942014	LABEL FUSE WARNING 1/2A SLO-BLO
1	942015	LABEL CAUTION ELECTRIC SHOCK
1	950011	MANUAL DSX
1	951001	WARRANTY CARD 5X7 ONE YEAR P+L

QNTY	PART#	LOCATION	DESCRIPTION
*	720063		PROCESSOR BOARD
2	151010	C54, 55	CAP ALUM ELECT 470 25V ET471X025A01
5	151024	C1, 2, 51, 52, 53	CAP ALUM ELECT 15 25V RADIAL
1	151028	C56	CAP ALUM ELECT 3300 50V AXIAL
1	151030	C17	CAP. ALUM-ELECT 1MF 50V
2	153004	C39, 44	CAP MYLAR FLM .01 C280AE/A10K
1	153008	C57	CAP MYLAR FLM .047 C280AE/A47K
5	153013	C19, 20, 42, 43, 49	CAP MYLAR FLM .1 C280AE/A100K
1	153014	C48	CAP MYLAR .0022
1	153020	C46	CAP MYLAR .0033 C280AEA3K3
3	157003	C12, 14, 45	CAP TANTALUM 6.8 MF 35V
3	157005	C16, 41, 50	CAP CER DISC 100 PF 1000V
1	157008	C40	CAP CER DISC 10 PF 1000V
2	157012	C11, 38	CAP CER DISC 30 PF 1000V
8	157019	C3-C10	CAP POLYPROP .022 MF 2.5% 160V
20	157021	C13, 15, 18, 21-37	CAP CER DIP .1 MF 20% 50V
1	157024	C47	CAP CER DISC 470 PF
1	217005	GND.	TERM FEEDTHROUGH-025 PIN CONCORD
2	219020	S18, 20	PHONE JACK 3C PCMOUNT SWRFTRN112BPC
18	219021	S1-S17, 19	PHONE JACK 2C PCMT SWRFT RN111PC
1	219314	CONN. D	CONN PCMT 4CKT M L.64 9-64-1042
1	219317	CONN. E	CONN PCMT 8CKT M L.64 9-64-1082
1	219324	CONN. C	CONN PCMT 13 CKT M L.64 09-64-1132
2	219901	U21, 80	IC SOCKET 8 PIN ICY-083-S3
24	219902	U16, 17, 19, 20, 23- U26, 28, 29, 33, 41- U44, 48, 51, 53, 54, U66, 67, 78, 79, 82	IC SOCKET 14 PIN ICY-143-S3
17	219903	U15, 18, 22, 27, 30, U31, 34, 39, 40, 45, U46, 47, 49, 50, 52, U81, R6-20	IC SOCKET 16 PIN ICY-163-S3
18	219906	U55-63, 68-76	IC SOCKET 24 PIN
2	219907	CONN. B, U65	IC SOCKET 40 PIN
5	219909	U32, 35-38	IC SOCKET 20 PIN AMP #640464-3

1	230001	X1	CRYSTAL 4.9152 MHZ
1	311017	U53	IC 74LS02 QUAD 2-IN NOR
1	311018	U50	IC 74LS139 DUAL 10F4 DECOD/DMULXR
2	311019	U34, 49	IC 74LS42 BCD-TO-DEC DECODER 16 PIN
2	311021	U66, 79	IC 74LS74 D F/F
1	311022	U67	IC 74LS04 HEX INVERTER
2	311028	U23, 24	IC 74LS05 QUAD O.C. INV FRT BUFFER
1	311029	U54	IC 74LS08 QUAD 3-INPUT AND GATE
1	311030	U29	IC 74LS27 TRI 3-IN NOR GATE
3	311031	U35, 36, 38	IC 74LS244 OCTAL 3-STATE BUFFER
1	311032	U37	IC 74LS245 OCTAL BUSS TRANSEIVER
1	311033	U32	IC 74LS374 OCTAL D FLIP-FLOP 3-S
1	311034	U78	IC 74LS393 DUAL 4BIT RIPPLE COUNTER
1	311035	U28	IC 74LS14 HEX SCHMITT TRIGGER
1	311036	U81	IC 74LS175 QUAD D FLIP-FLOP
1	313003	U80	IC 1458 DUAL OP AMP RC1458DN
1	313014	U82	IC 723 VOLTAGE REG GEN PURP ML723CP
2	313022	U16, 20	IC 324 QUAD OP AMP LM324N
2	313024	U17, 19	IC TLO84 QUAD BI FET OP AMP TLO84CN
1	313025	U21	IC TLO81 SING BI FET OP AMP TLO81CN
1	313035	Z1	IC 329 ZENER REF DIODE LM329CZ
1	313036	U83	IC 7812 POWER REG +12V
1	313044	U84	IC 7912 POWER REG-12V TO220
3	315002	U41, 43, 44	IC 4011 QUAD 2IN NAND MC14011CP
3	315006	U25, 26, 48	IC 4013 DUAL TYPE D F/F MC14013CP
3	315015	U30, 31, 52	IC 74C174 HEX D F/F MM74C174
1	315025	U18	IC 4051 ANAL MULTI-DEMULTI CD4051BE
2	315026	U42, 51	IC 4NORGATE MC14001BCP/CD4001BE OLY
1	315027	U40	IC PRESET /N COUNT NSC CD4018BCP
1	315028	U39	IC 4099 8-BIT ADDRESSABLE REG
2	315029	U45, 46	IC 74C42 BCD-TO-DECIMAL DECODER
1	315035	U22	IC DAC1020 10 BIT DAC
1	315038	U33	IC 4066 QUAD BILAT SWITCH
2	315041	U27, 47	IC 40103 8-STAGE DOWN COUNTER
1	315042	U15	IC 40109 QUAD LEVAL SHIFTER
1	316001	U65	MICROPROCESSOR Z80 MOSTEK MK3880N
1	317006	U75	EPROM 2716 2048X8
8	317009	U55-58, 68-71	RAM 6116 2KX8 CMOS HM6116F-4
2	317010	U63, 76	EPROM 2732 4KX8
1	401004	BAT.	BATTERY 4.8V NICAD GOULD 402037-004
1	471361	R124	RESISTOR FXD 1/2W 2-5% 360 OHM
1	475302	R4	RESISTOR FXD 1.00K 1% 1/8W
1	475326	R118	RESISTOR FXD 1.78K 1% 1/8W
1	475369	R117	RESISTOR FXD 4.87K 1% 1/8W
1	475414	R1	RESISTOR FXD 13.3K 1% 1/8W
1	476011	T1	TRIMMER 100K 375E104B CERMET
1	476012	T3	TRIMMER 1K 375E102B CERMET
1	476020	T2	TRIMMER 5K A-B MT2P502
2	478010	R120, 121	RESISTOR FXD 1/4W 2-5% 1 OHM
1	478022	R41	RESISTOR FXD 1/4W 2-5% 2.2 OHM
1	478101	R58	RESISTOR FXD 1/4W 2-5% 100 OHM
2	478102	R102, 113	RESISTOR FXD 1/4W 2-5% 1K

6	478103	R35, 40, 62, 95, R103, 104	RESISTOR FXD 1/4W 2-5% 10K
2	478104	R44, 101	RESISTOR FXD 1/4W 2-5% 100K
1	478105	R60	RESISTOR FXD 1/4W 2-5% 1 MEG
1	478122	R76	RESISTOR FXD 1/4W 2-5% 1.2K
1	478152	R115	RESISTOR FXD 1/4W 2-5% 1.5K
1	478154	R94	RESISTOR FXD 1/4W 2-5% 150K
1	478220	R78	RESISTOR FXD 1/4W 2-5% 22 OHM
1	478221	R77	RESISTOR FXD 1/4W 2-5% 220 OHM
1	478222	R114	RESISTOR FXD 1/4W 2-5% 2.2K
2	478223	R108, 109	RESISTOR FXD 1/4W 2-5% 22K
1	478224	R100	RESISTOR FXD 1/4W 2-5% 220K
1	478225	R61	RESISTOR FXD 1/4W 2-5% 2.2 MEG
1	478332	R3	RESISTOR FXD 1/4W 2-5% 3.3K
5	478333	R96, 99, 107, R111, 112	RESISTOR FXD 1/4W 2-5% 33K
2	478471	R122, 123	RESISTOR FXD 1/4W 2-5% 470 OHM
29	478472	R5, 21, 22, 32-34, R36-39, 42, 45, 46, R56, 57, 59, 63-66, R90-93, 105, 106, 110, 116, 119	RESISTOR FXD 1/4W 2-5% 4.7K
3	478473	R43, 97, 98	RESISTOR FXD 1/4W 2-5% 47K
1	478475	R2	RESISTOR FXD 1/4W 2-5% 4.7 MEG
2	478821	R79, 80	RESISTOR FXD 1/4W 2-5% 820 OHM
3	479003	R47-55, 67-75, R81-89	RESISTOR NETWORK 4.7K SIP
1	479005	R23-31	RESISTOR NETWORK 10K SIP 10 PIN
1	479006	R6-20	RESISTOR NETWORK 470 OHM DIP
14	481001	D1-10, 12-15	DIODE SIGNAL 1N4148
1	482015	D11	DIODE GERMANIUM 1N34A
1	482016	Z2	DIODE ZENER 5.6V 1N752A
2	483006	CR1, CR2	RECTIFIER BRIDGE GI-W02M
8	485003	Q2, 4-8, 10, 11	TRANSISTOR SS NPN MPS5172
1	486001	Q1	TRANSISTOR SS PNP 2N3638A
2	486002	Q3, 9	TRANSISTOR SS PNP 2N3905
1	651547		DSX CONTROL PCB 1545-1546
1	750152	CONN. A	CABLE SUB-ASSY DSX #5
1	930019		PRCHD OUTSD LABOR DSX PROCESSOR
4			CABLE TIES FOR CAPACITORS

QNTY	PART#	LOCATION	DESCRIPTION
* 1	720064		POT BOARD
1	157003	C1	CAP TANTALUM 6.8 MF 35V
1	217005	GND.	TERM FEEDTHROUGH-025 PIN CONCORD
1	219501	CONN. A	CONN RIBBON 34P RIGHT ANGLE HEADER
7	219903	U1, 2, 7-10, CONN B	IC SOCKET 16 PIN ICY-163-S3
4	219909	U3-6	IC SOCKET 20 PIN AMP #640464-3

4	241008	U11-14	DISPLAY ALPHANUMER LITRONIX DL1414
1	245105	D36	LED RED 1/8R TI TIL216-1
3	311019	U7-9	IC 74LS42 BCD-TO-DEC DECODER 16 PIN
4	311033	U3-6	IC 74LS374 OCTAL D FLIP-FLOP 3-S
1	315015	U10	IC 74C174 HEX D FLIP-FLOP MM74C174
2	315030	U1,2	IC 80C98 TRI-STATE INVERTER 16 PIN
28	470221	R1-3, 11-34, 36	RESISTOR FXD 1/4W 2-5% 220 OHM
8	470472	R4-10, 35	RESISTOR FXD 1/4W 2-5% 4.7K
35	481001	D1-35	DIODE SIGNAL 1N4148
27	510010	SW1-27	SWITCH PUSH ON MOM SPDT STL-BLK-RED
1	511002	SW28-34	SWITCH DIP 8POS ROCKER RECESSED
1	651540		DSX FRONT PANEL PCB 1538-1539

QNTY	PART #	DESCRIPTION
*	730105	MECH SUB-ASSY DSX TRANSFORMER
1	211045	CONN 8 CKT NAT 09-50-7081
1	211207	POLARIZING KEY MOLEX2560 15-04-0219
6	211210	CONN TER F 18 CRIMP 2478 08-50-0106
1	561020	POWER XFMR DMX/DSX EX 1627

QNTY	PART #	DESCRIPTION
*	730106	MECH SUB-ASSY DSX REGULATOR
1	261008	HEAT SINK DSX/DMX
2	281018	SCREW 6-32X5/16 PHIL PAN BLK OX
2	281050	SCREW 6-32X3/8 PHIL PAN BLK OX
1	289010	SOLDER LUG #6 SCREW CLEAR BT 1414-6
1	289026	INSULATOR FOR TO-3 TRANSIS DBX-103
1	289032	MOUNTING INSULATOR TO-3 INS-3
1	487008	TRANSISTOR PWR NPN 2N3055
1	750150	CABLE SUB-ASSY DSX # 3

QNTY	PART #	DESCRIPTION
*	750148	CABLE SUB-ASSY DSX #1
1	219513	CONN RIBBON 40P MALE DIP
1	219515	CONN RIBBON 37P D-SUR SOCKET
5	605040	CABLE RIBBON 40 COND 28 AWG

QNTY	PART #	DESCRIPTION
*	750149	CABLE SUB-ASSY DSX # 2
1	211046	CONN 13 CKT NAT 09-50-7131
1	211207	POLARIZING KEY MOLEX2560 15-04-0219
12	211210	CONN TER F 18 CRIMP 2478 08-50-0106
2	219004	PHONE JACK 2 CONDUCT MIN ENCL 142A
1	219007	PHONE JACK 3 CONDUCT ENCLOSED 114B
1	219015	PHONE JACK 3C ENCLSD SCRFT 112B
2	510407	SWITCH SL DPDT SHORT SWRT 46206LSR
1	510408	SWITCH SL DPDT FLUSH SWRFT 11A1211
18	604000	WIRE 24 7/32 BLK PVC U
3	604000	WIRE 24 7/32 BLK PVC U
14	604100	WIRE 24 7/32 BRN PVC U
18	604100	WIRE 24 7/32 BRN PVC U
14	604200	WIRE 24 7/32 RED PVC U
14	604200	WIRE 24 7/32 RED PVC U
5	604200	WIRE 24 7/32 RED PVC U
14	604300	WIRE 24 7/32 ORN PVC U
15	604400	WIRE 24 7/32 YEL PVC U
15	604500	WIRE 24 7/32 GRN PVC U
16	604600	WIRE 24 7/32 BLU PVC U
16	604700	WIRE 24 7/32 VIO PVC U
13	604800	WIRE 24 7/32 GRY PVC U
18	604900	WIRE 24 7/32 WHT PVC U

QNTY	PART #	DESCRIPTION
*	750150	CABLE SUB-ASSY DSX # 3
1	211036	CONN 4 CKT NAT 09-50-7041
1	211207	POLARIZING KEY MOLEX2560 15-04-0219
3	211210	CONN TER F 18 CRIMP 2478 08-50-0106
3	289019	CABLE TIE 4" OVERALL LENGTH T1BR
12	608100	WIRE 20 19/32 BRW PVC U
12	608300	WIRE 20 19/32 ORN PVC U
12	608400	WIRE 20 19/32 YEL PVC U

QNTY	PART #	DESCRIPTION
*	750151	CABLE SUB-ASSY DSX # 4
2	219514	CONN RIBBON 37P D-SUB PLUG
72	605040	CABLE RIBBON 40 COND 28 AWG

QNTY	PART #	DESCRIPTION
*	750152	CABLE SUB-ASSY DSX #5
1	219502	CONN RIBBON 34P STANDARD FEMALE
1	219503	CONN RIBBON 34P SOLDER TO BOARD
9	605034	CABLE RIBBON 34 COND 28 AWG

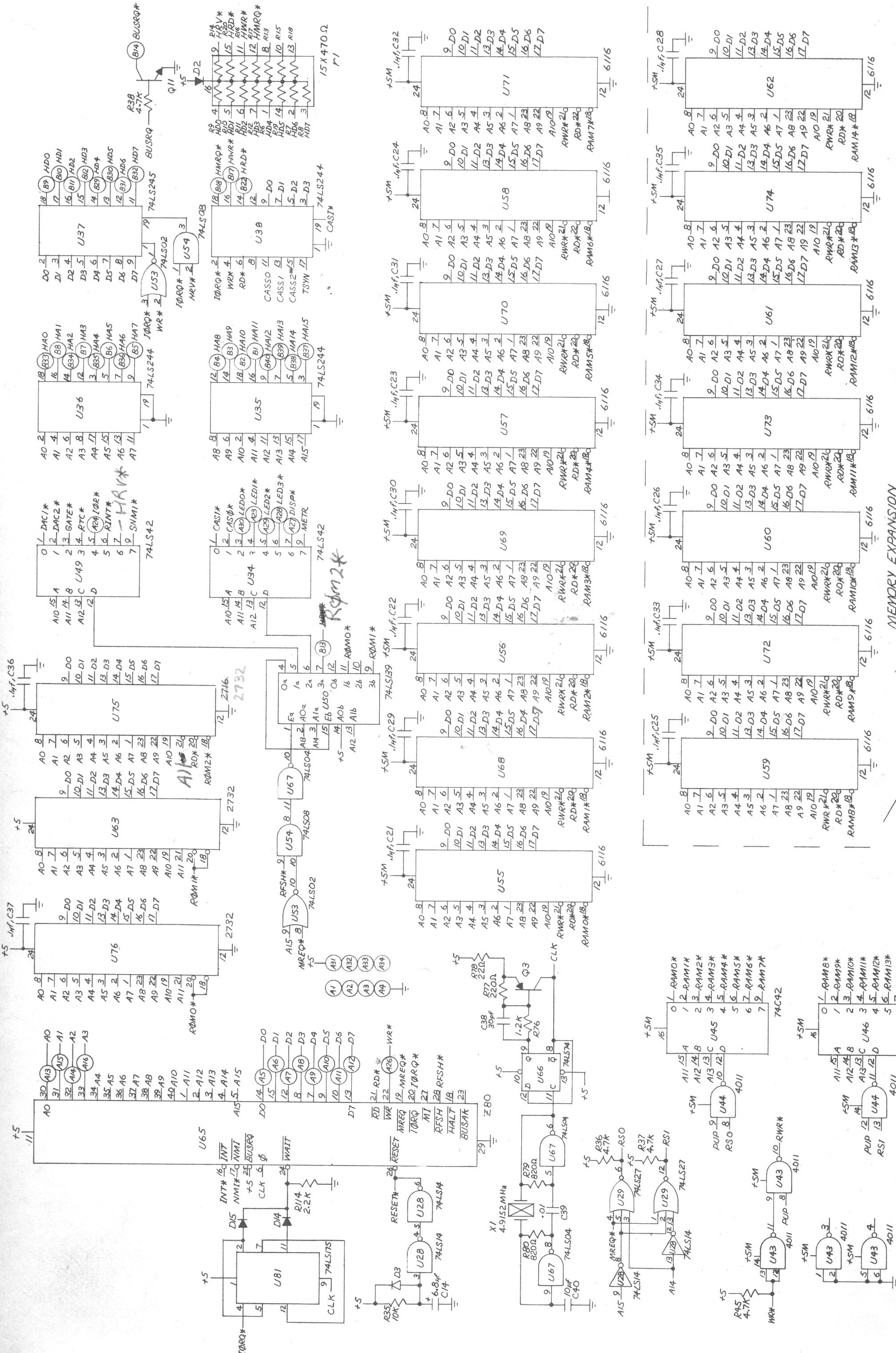

MEMORY EXPANSION

- UNLESS OTHERWISE SPECIFIED
1. ALL NPN TRANSISTORS ARE MPS5172
 2. ALL PNP TRANSISTORS ARE 2N3905
 3. ALL DIODES ARE 1N4148
 4. ALL RESISTORS ARE 1/4 W, 5%

LTR	REVISION	DATE	SHEET / OF 3
A	INITIAL RELEASE	12-1-81	1

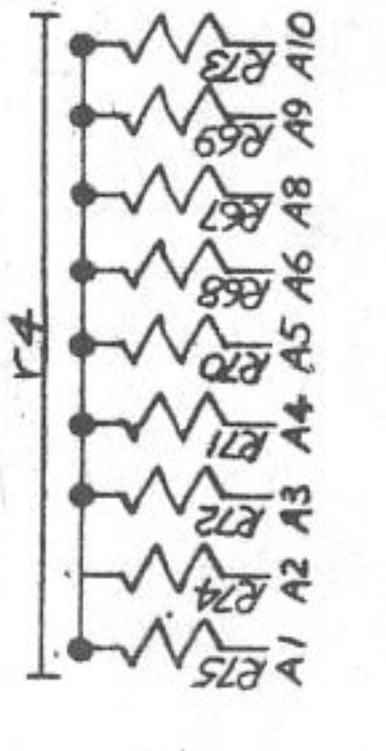
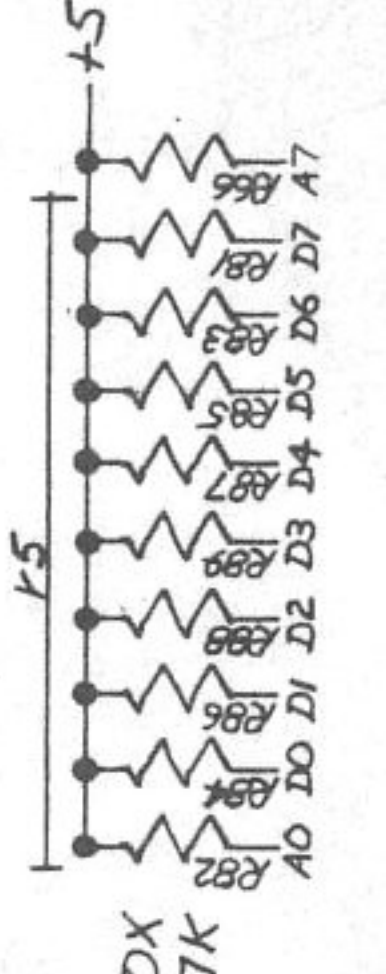

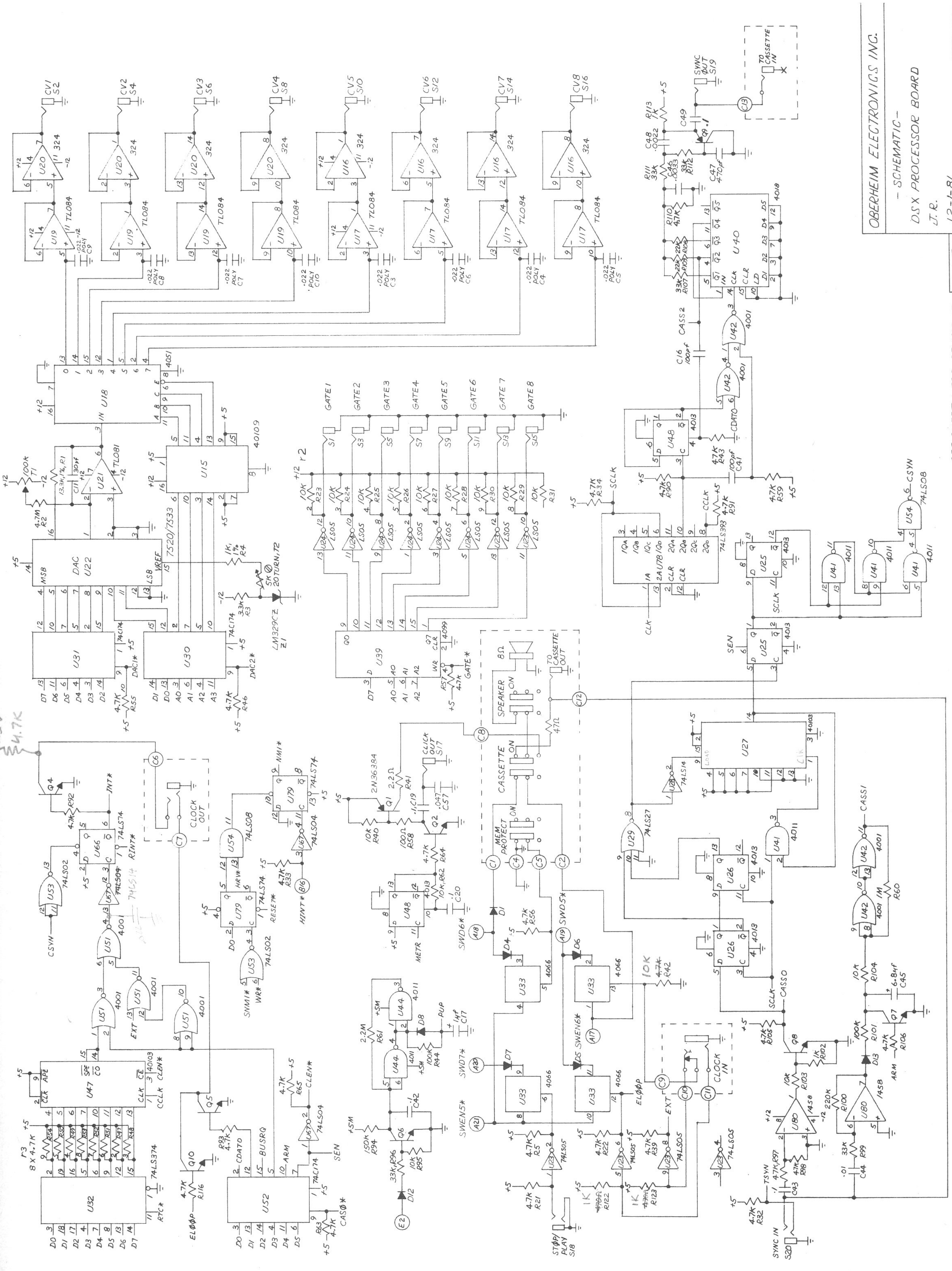

OBERHEIM ELECTRONICS INC.

- SCHEMATIC -
DSX PROCESSOR BOARD
J.R.

SEE SHEET 1 FOR REVISIONS

1591A

SHEET

12-1-81

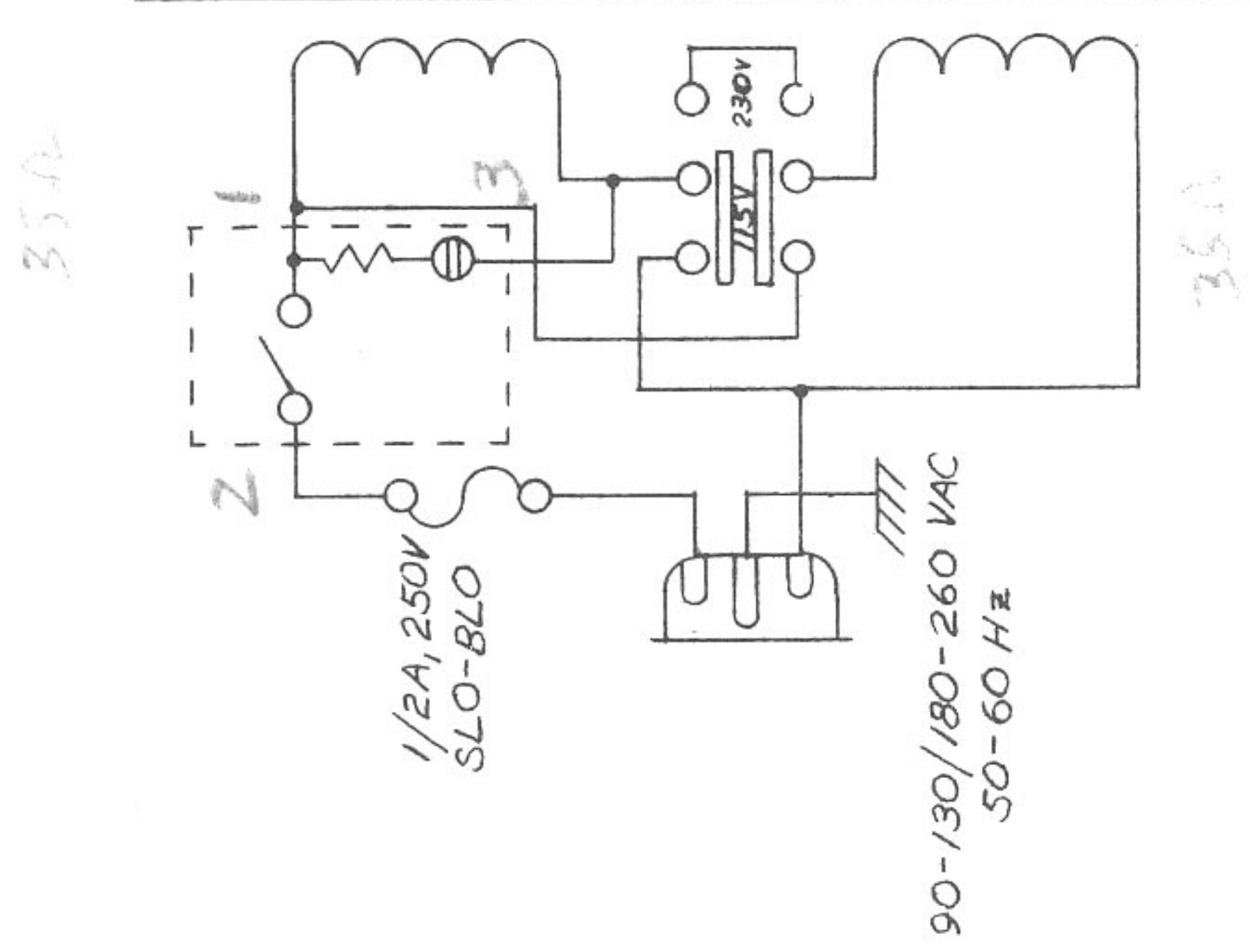
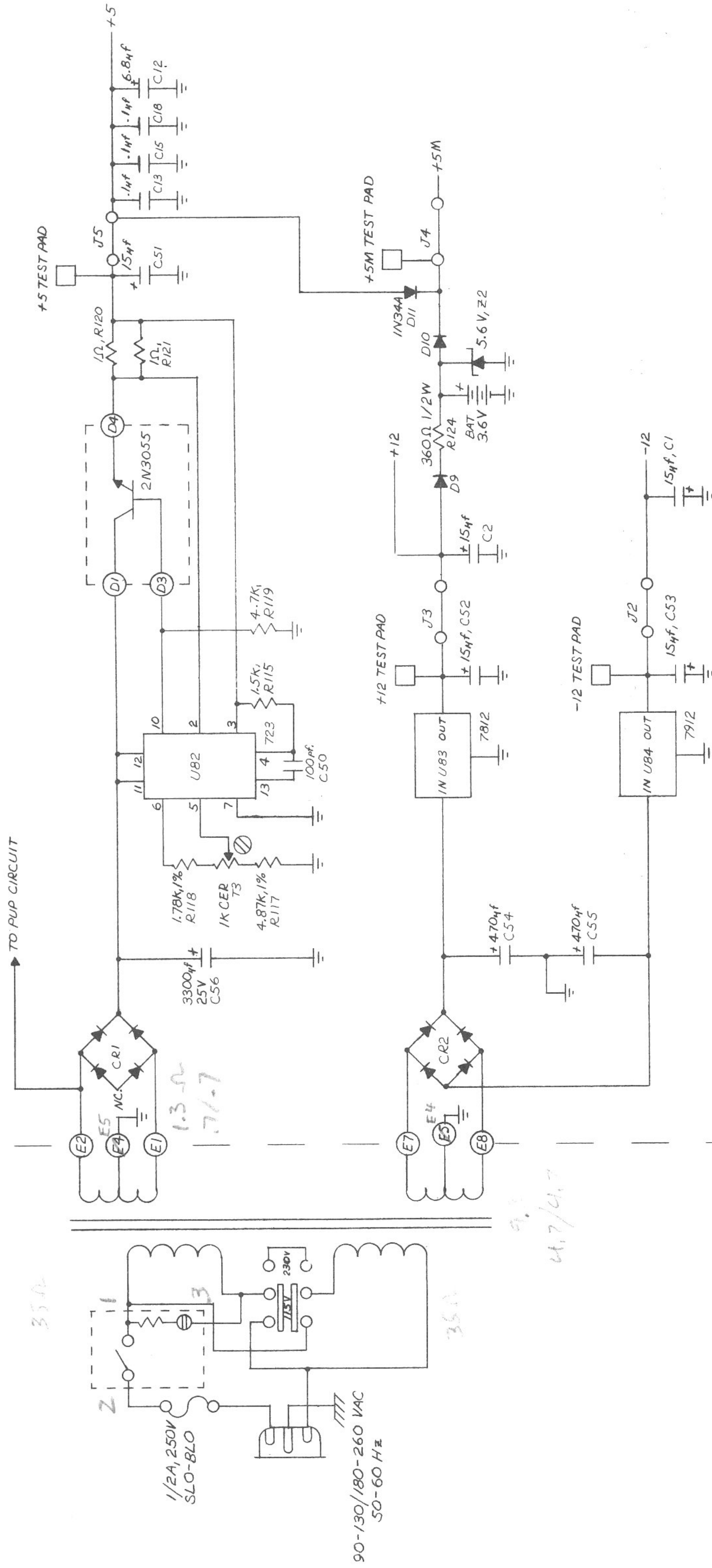

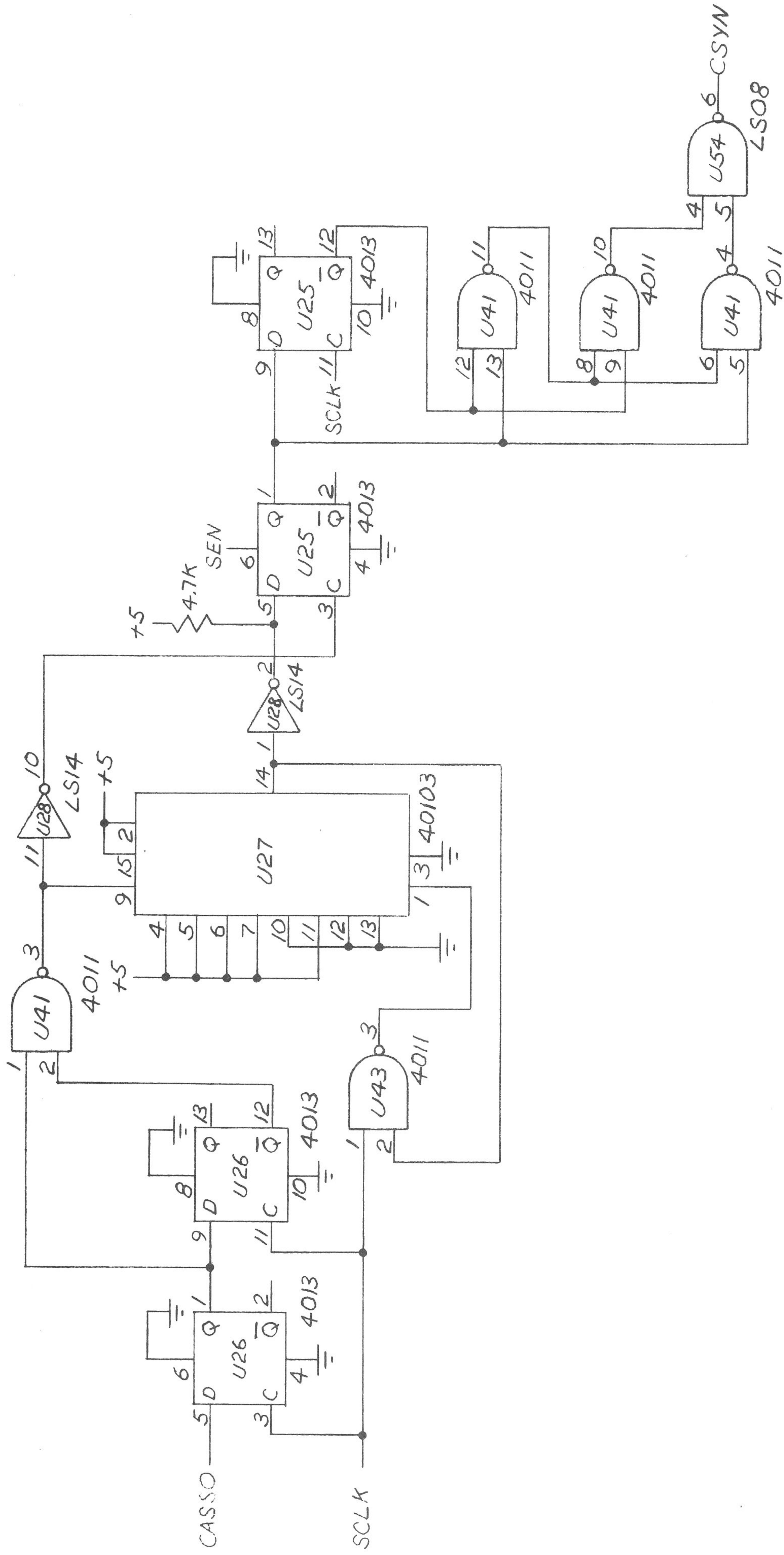

OBERHEIM ELECTRONICS INC.

-SCHEMATIC-

DSX EARLY SYNC.

J. R.

12-1-81

1595A

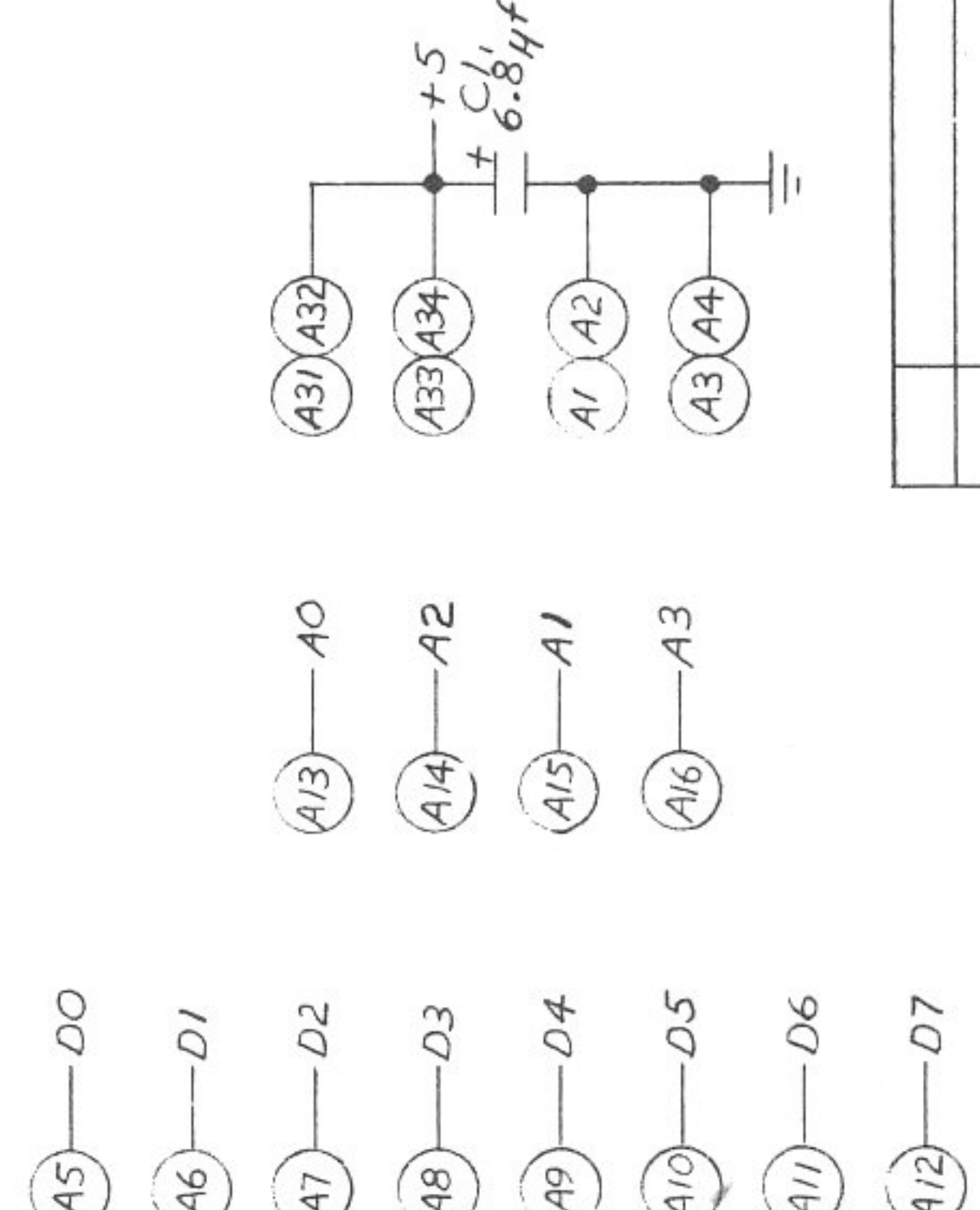
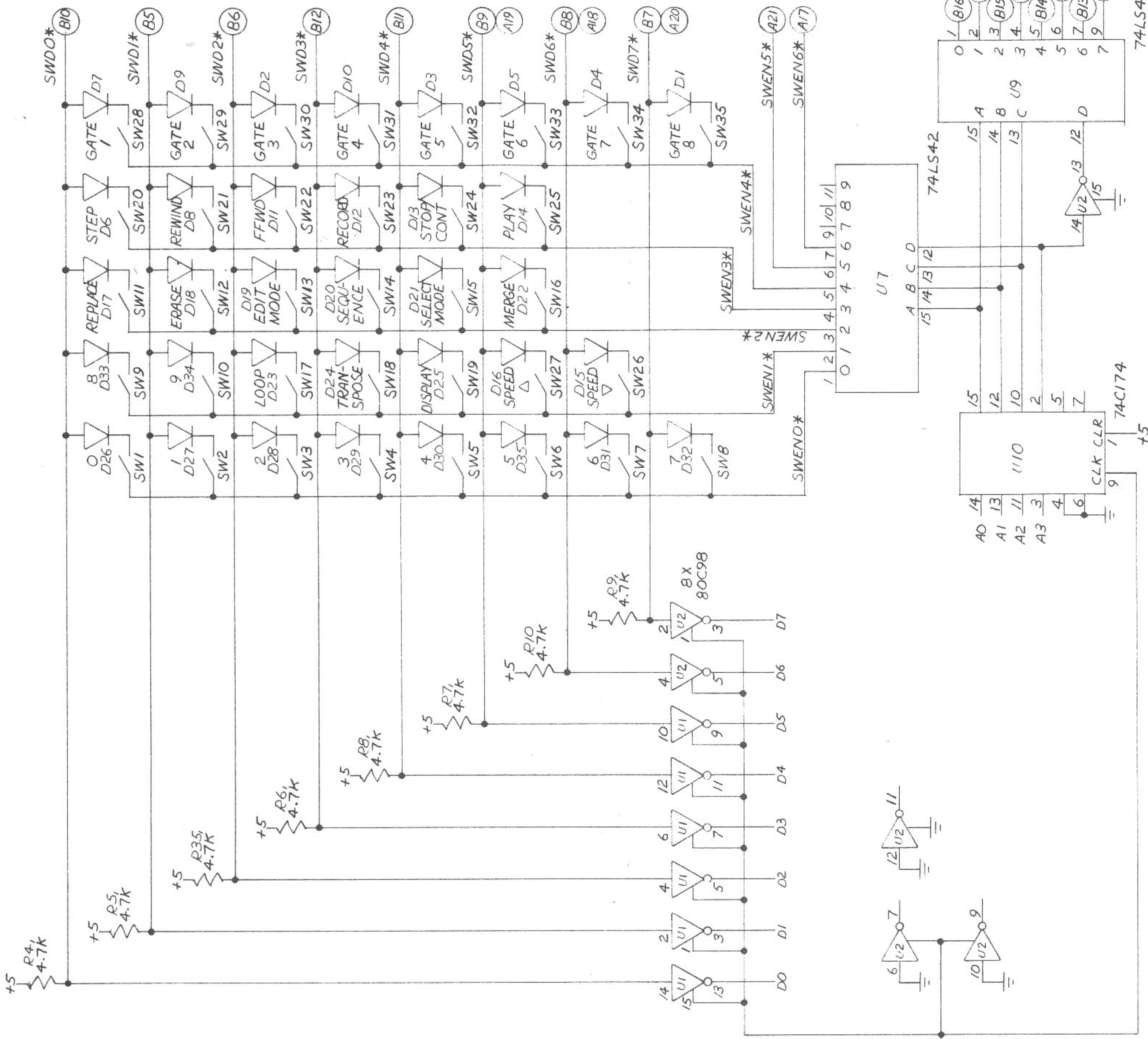

- UNLESS OTHERWISE SPECIFIED
1. THE (60p) CONNECTOR IS THE EXTERNAL KEYBOARD CONNECTOR.
 2. ALL DIODES ARE IN4148
 3. ALL RESISTORS ARE 1/4 W, 5%

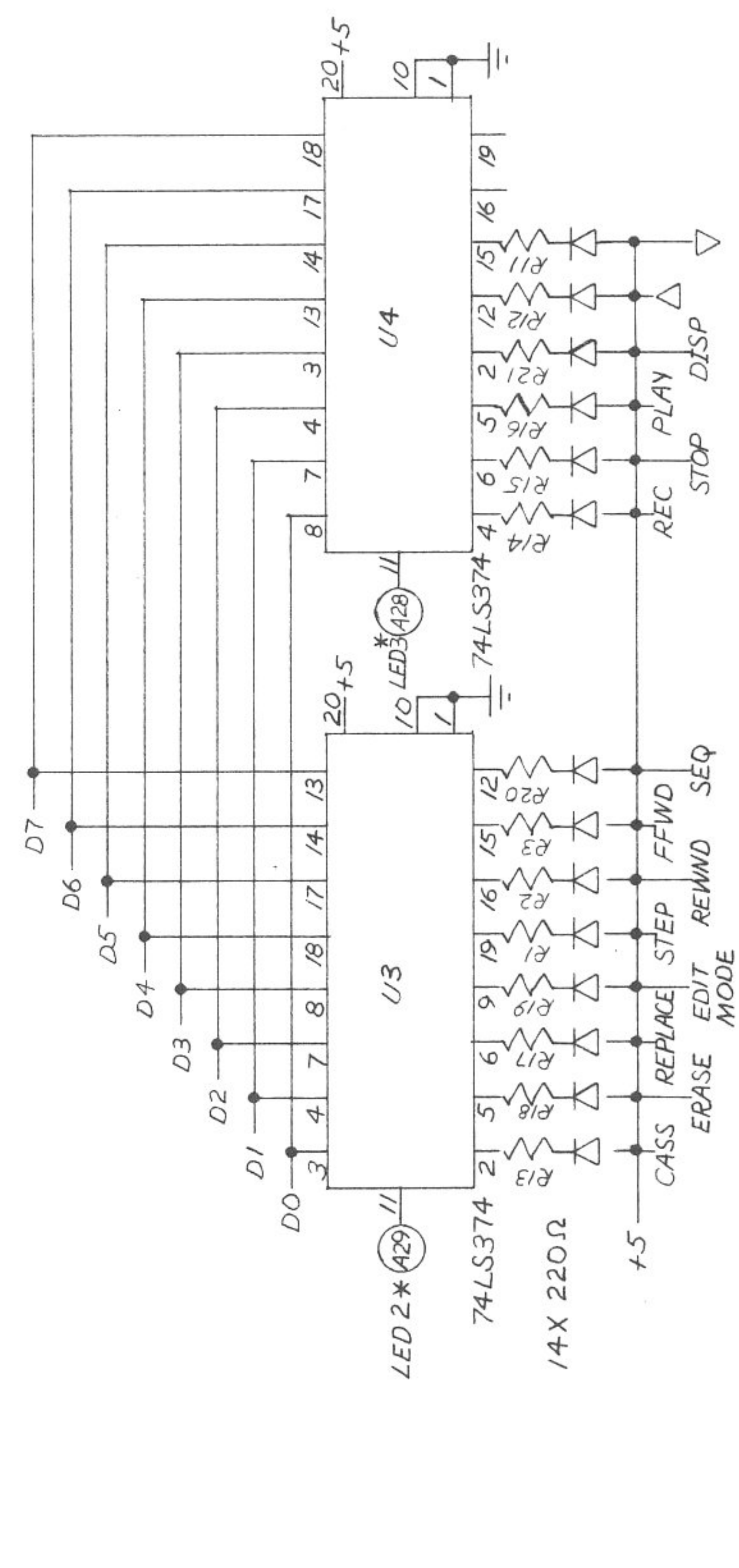
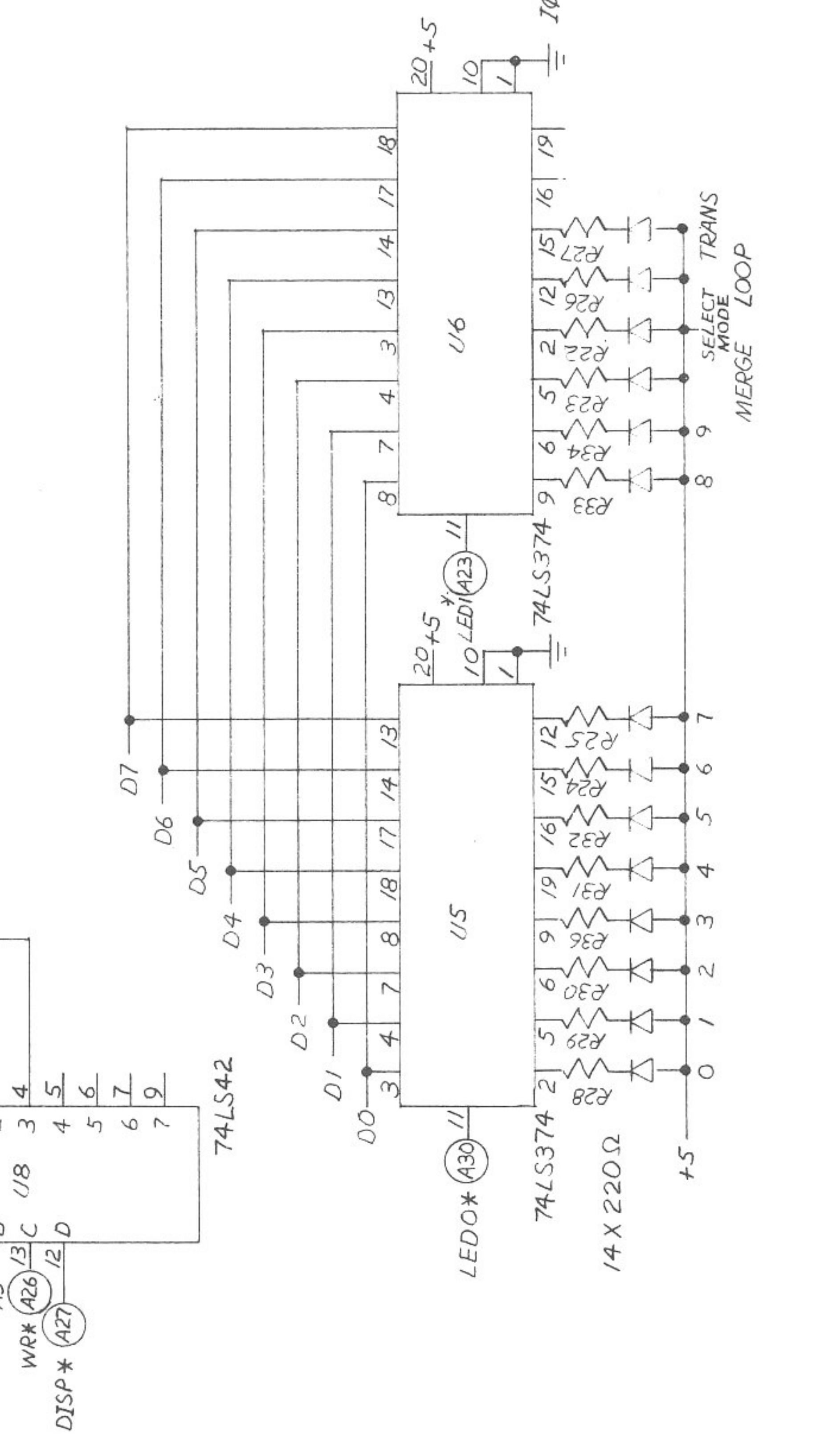
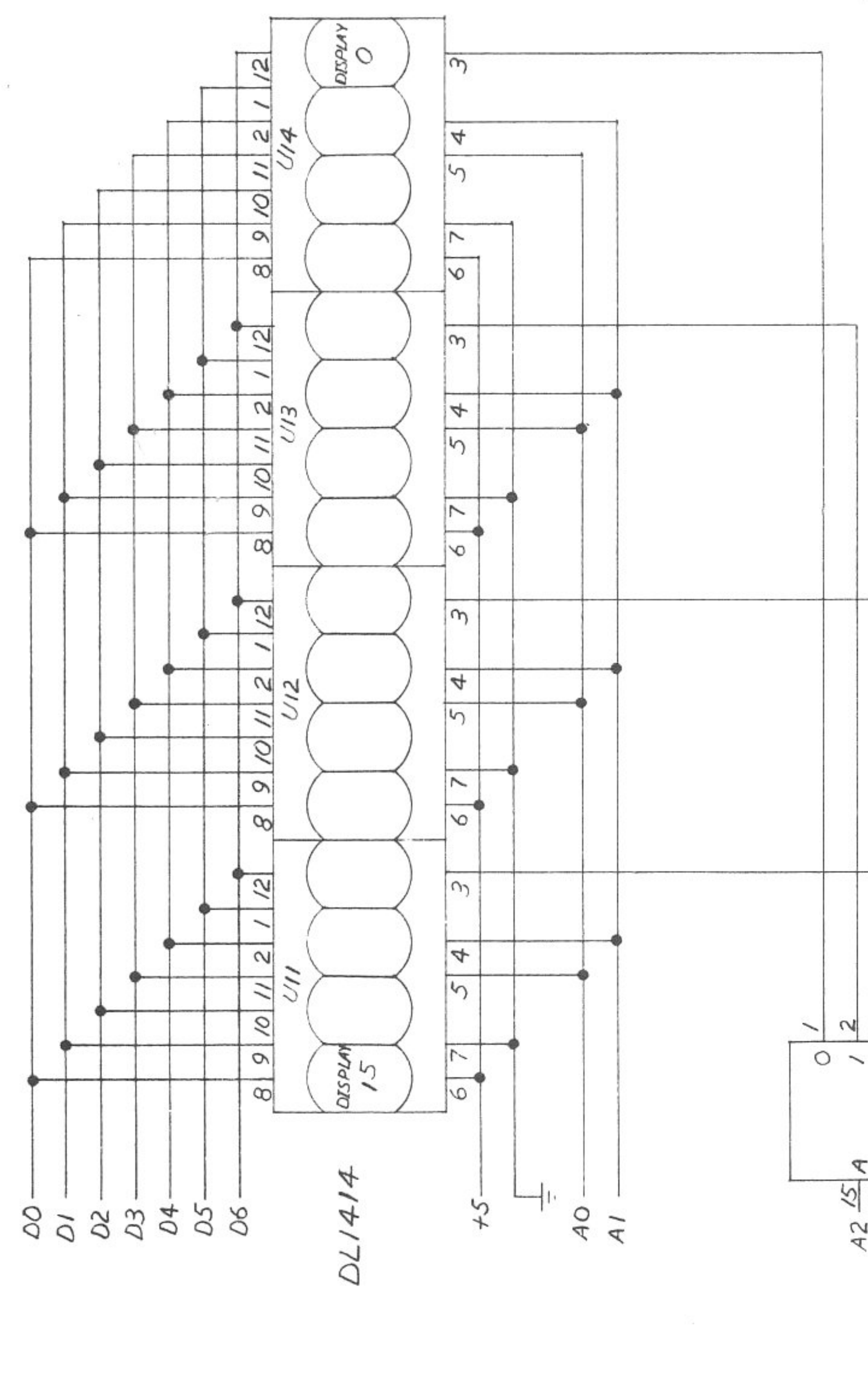

LTR	REVISION	DATE
A	INITIAL RELEASE	12-1-81

OBERHEIM ELECTRONICS INC.
 -SCHEMATIC-
 DSX SWITCH BOARD
 J.R.
 12-1-81

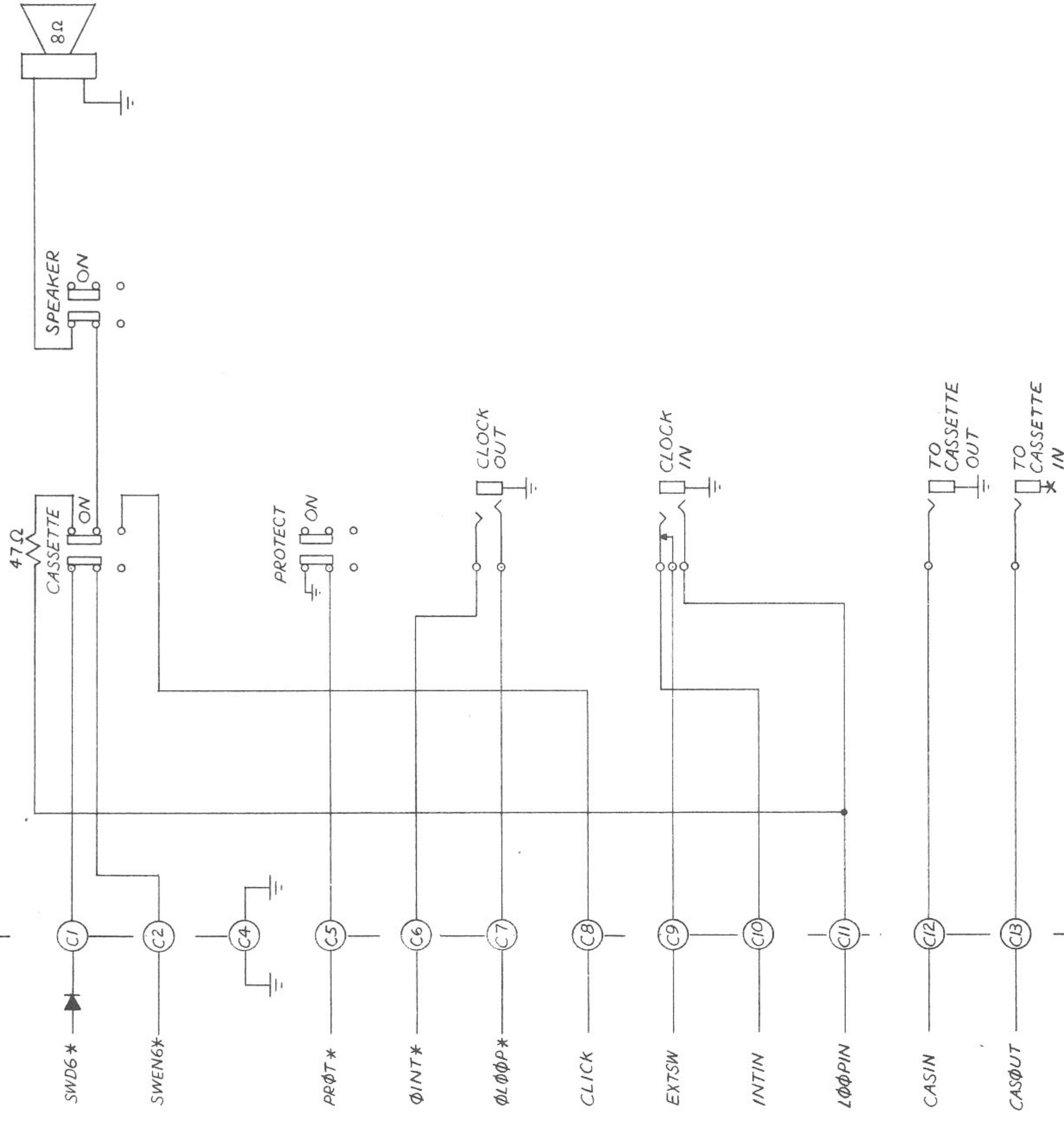

PROCESSOR BOARD REAR PANEL

OBERHEIM ELECTRONICS INC.
 -SCHEMATIC-
 DSX REAR PANEL
 J. R.
 12-1-81

LTR	REVISION	DATE
A	INITIAL RELEASE	12-1-81

1593A

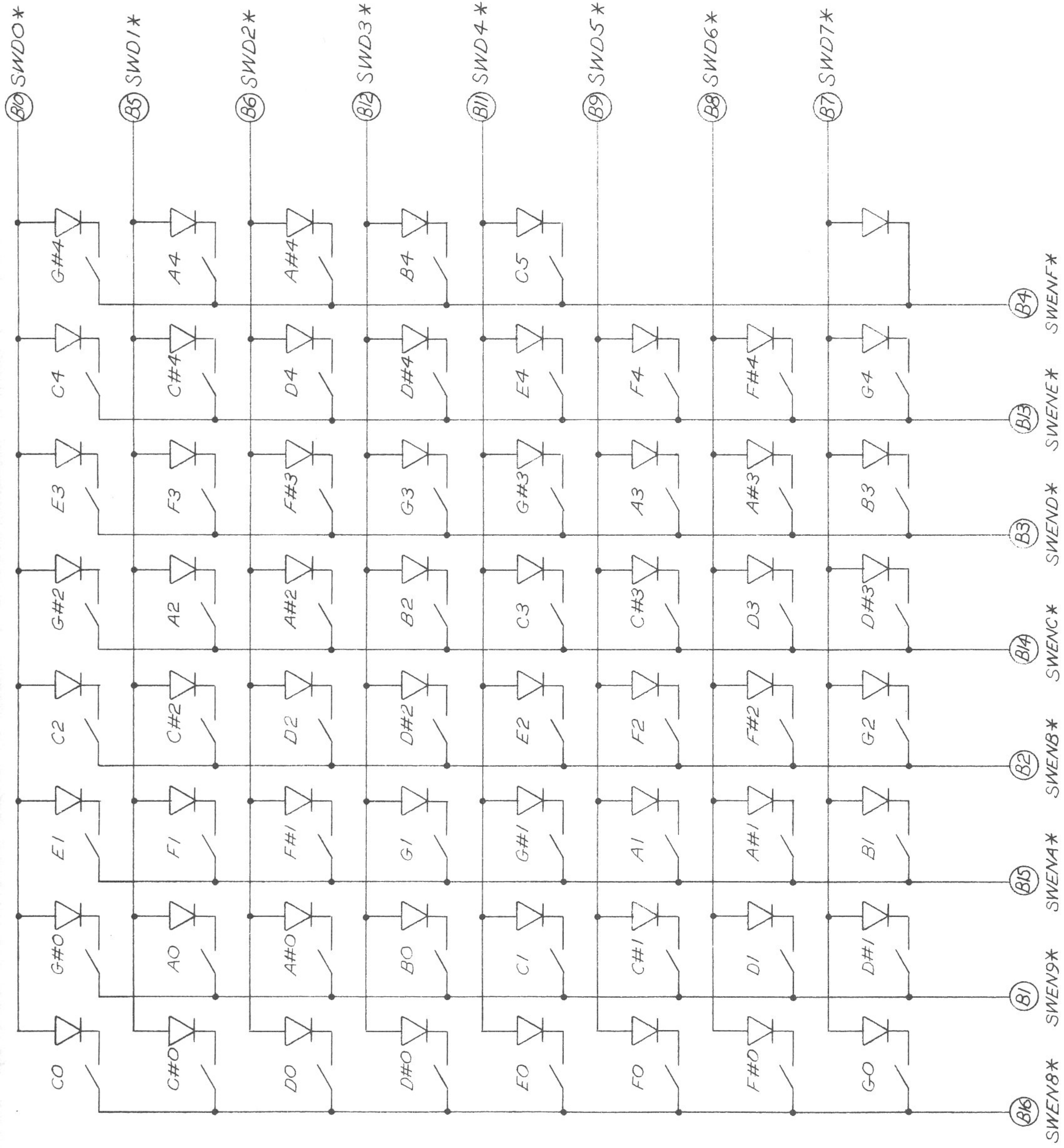

A	INITIAL RELEASE	12-1-81
LTR	REVISION	DATE

OBERHEIM ELECTRONICS / INC.
 -SCHEMATIC-
 DSX EXTERNAL KEYBOARD
 J.R.
 12-1-81

1594A

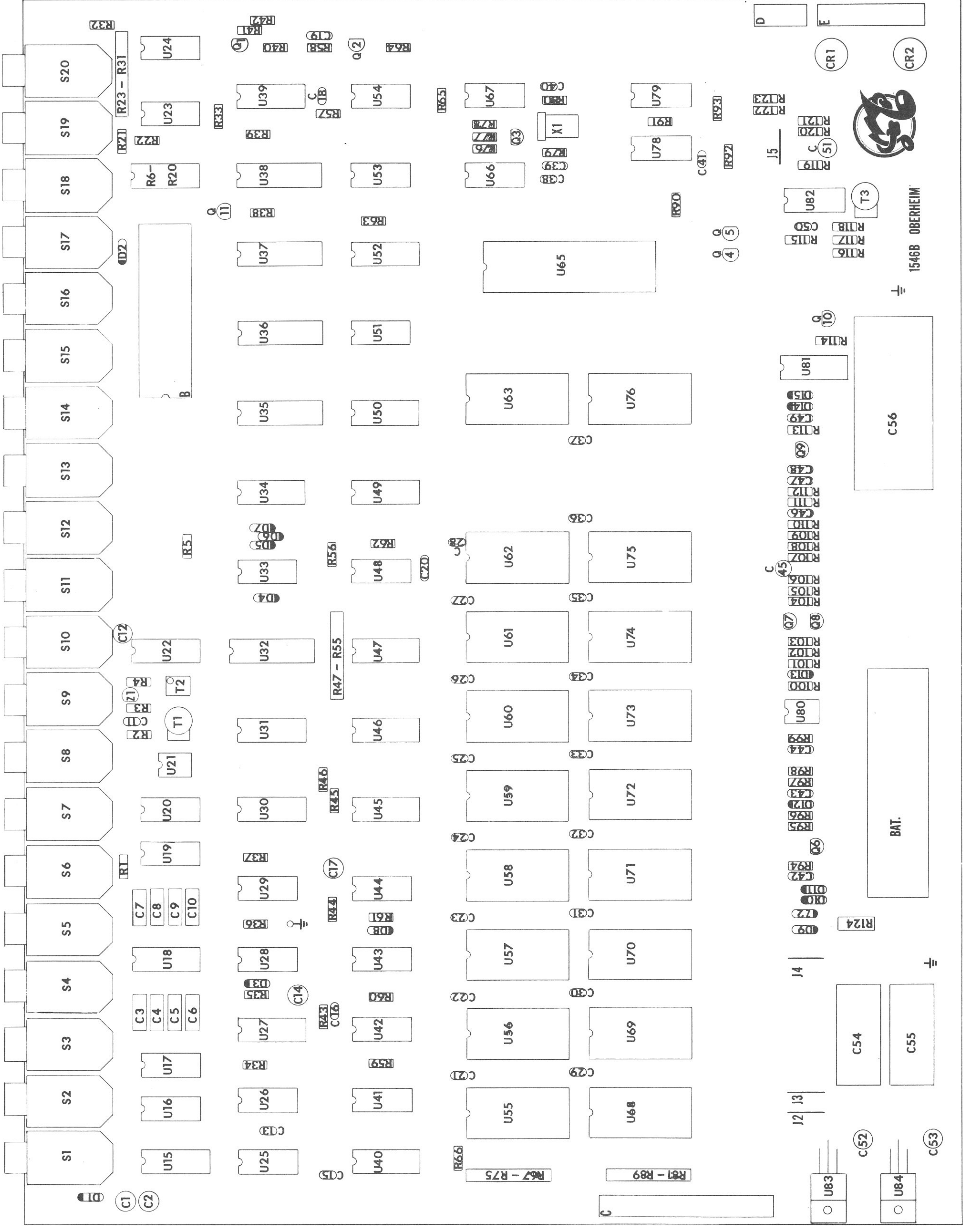

OBERHEIM ELECTRONICS INC.

- PARTS LAYOUT -

DSX PROCESSOR BOARD

J.R.

12-1-81

LTR	REVISION	DATE
A	INITIAL RELEASE	12-1-81

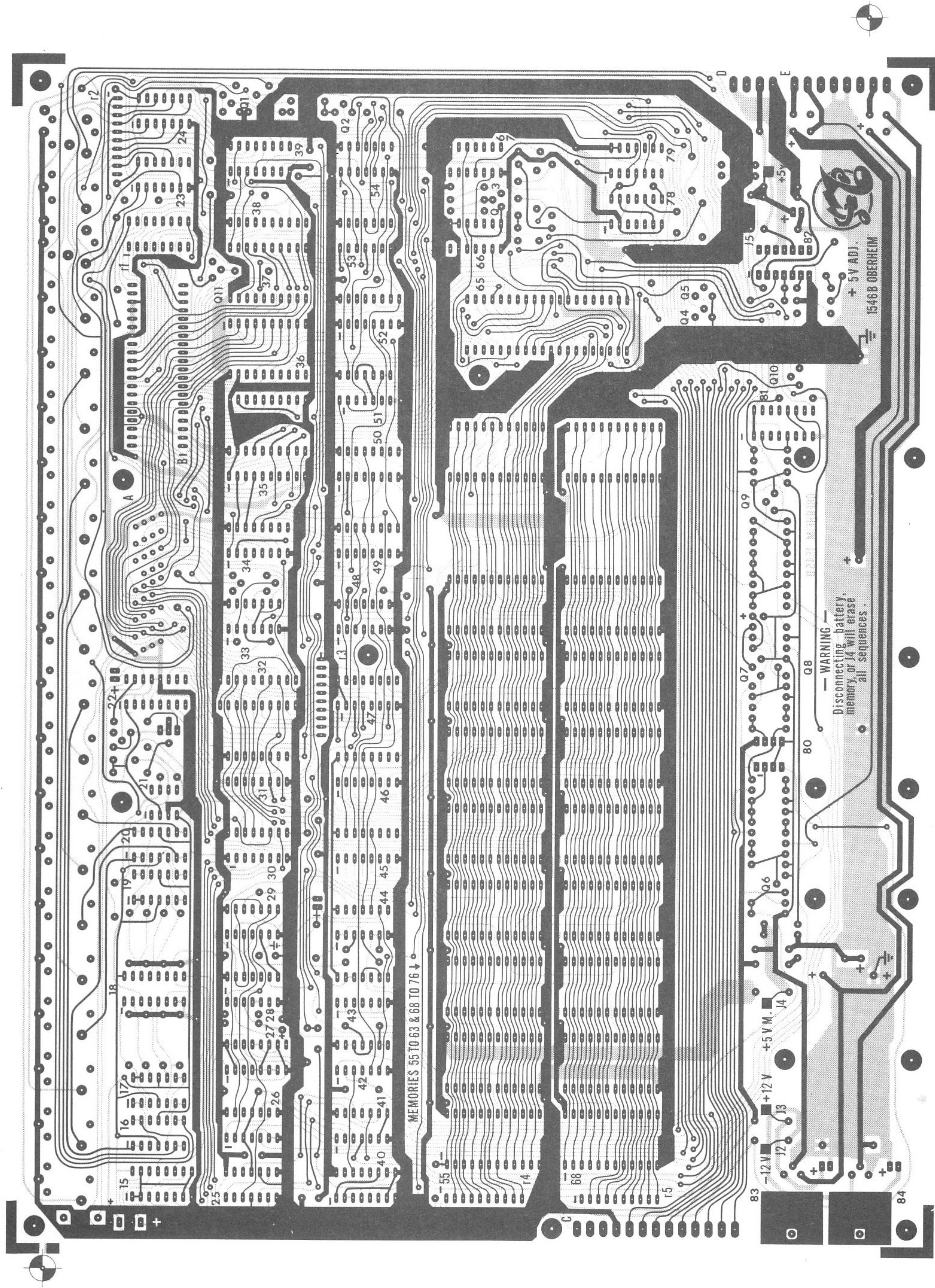

<i>OBERHEIM ELECTRONICS INC.</i>	
SCALE:	APPROVED BY:
DATE: 12-1-81	DRAWN BY:
	REVISED:
<i>P.C. COMPOSITE</i>	
<i>D.S.X PROCESSOR BOARD</i>	
	DRAWING NUMBER <i>1598A</i>

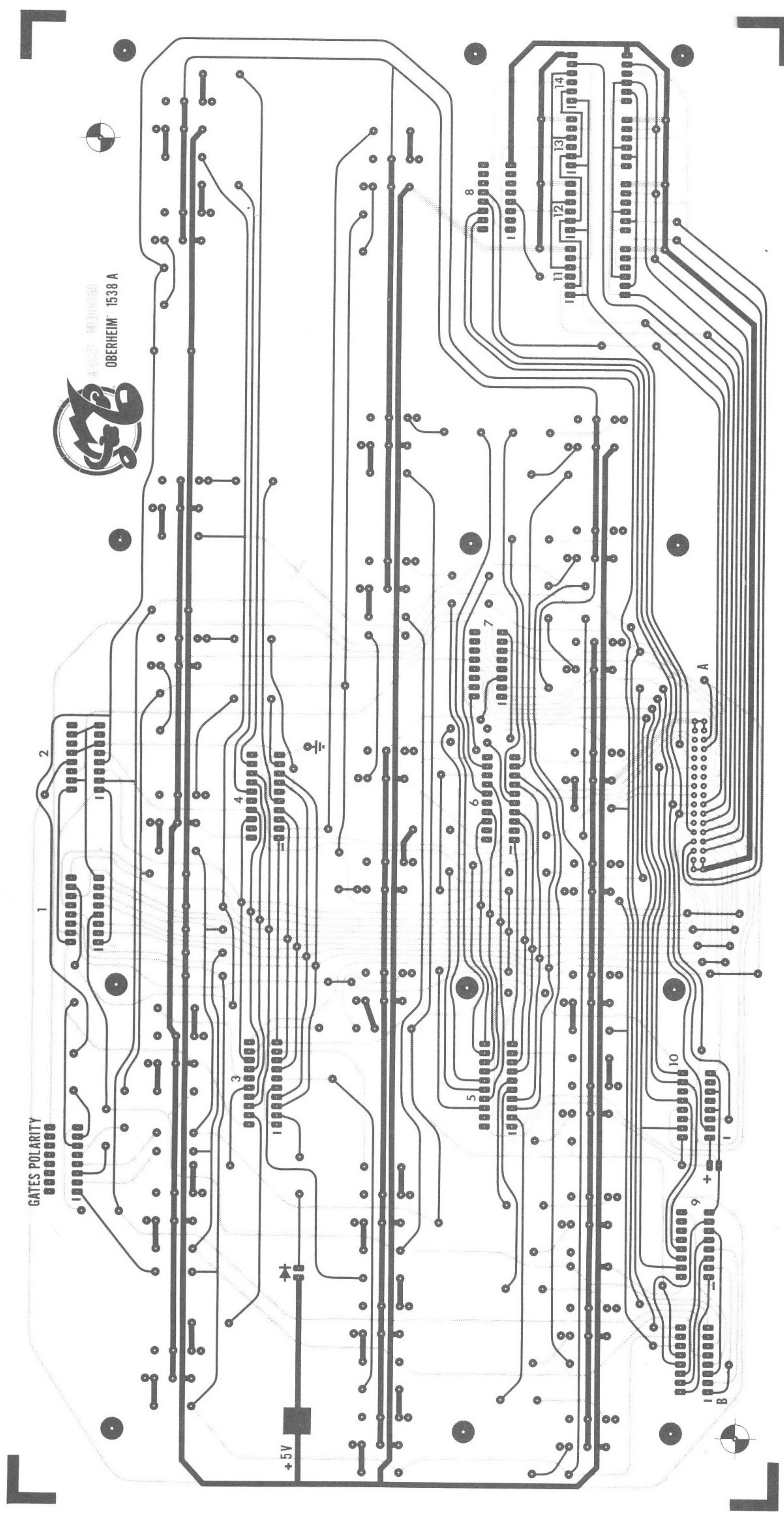

OBERHEIM ELECTRONICS INC.	
SCALE:	APPROVED BY:
DATE 12-1-81	DRAWN BY:
	REVISED:
P.C. COMPOSITE	
D SX SWITCH BOARD	
	DRAWING NUMBER 1599A

OBERHEIM ELECTRONICS, INC.
ENGINEERING CHANGE ORDER

ECO NO.
201

PRODUCT AFFECTED

DSX

DRAWINGS AFFECTED

DESCRIPTION OF CHANGE

Change 1N4148 diode in battery backup circuit to 1N4002 (or equiv.).

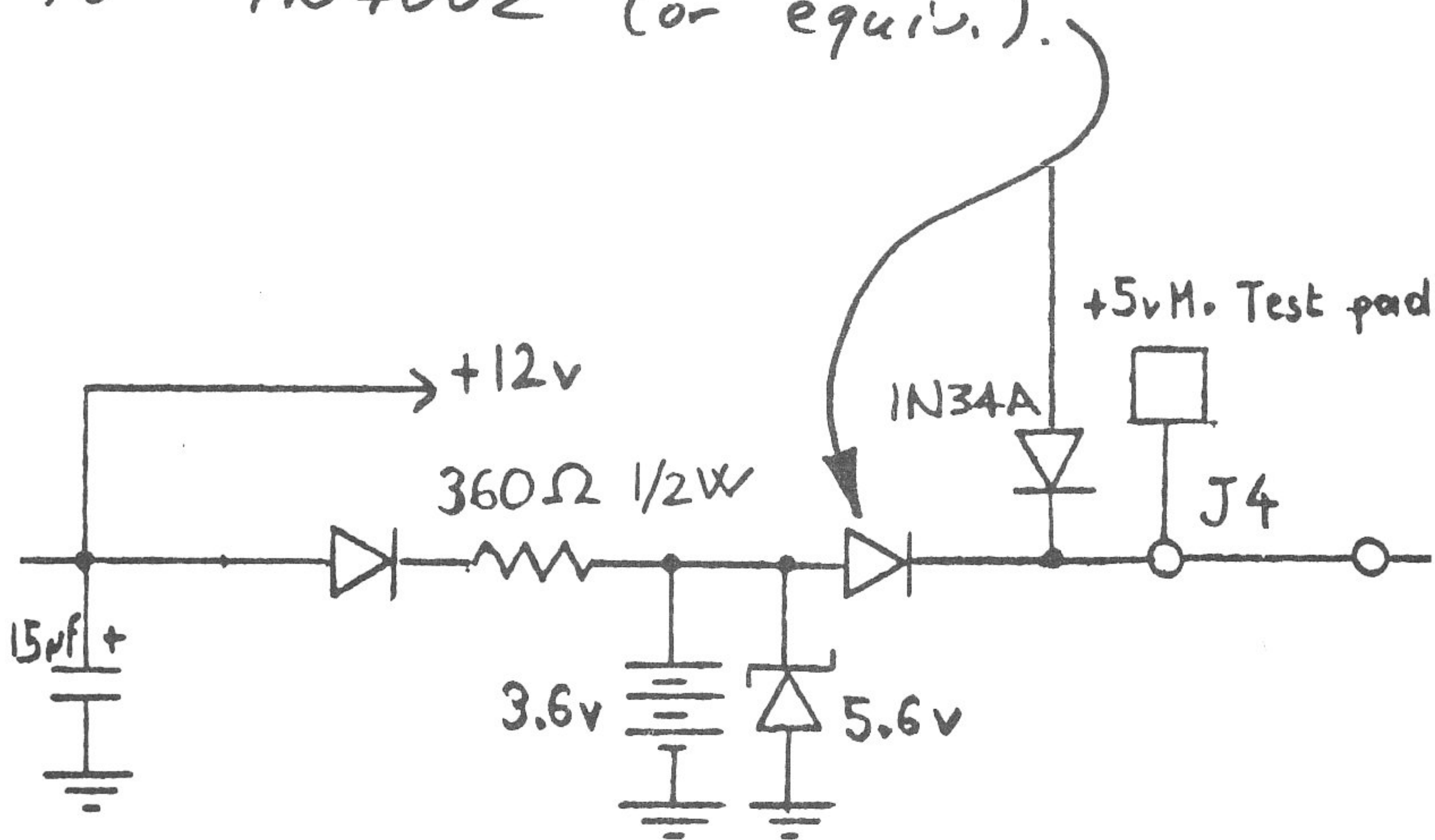

REASON FOR CHANGE

Occasionally the 1N4148 opens & then battery backup does not work.

EFFECTIVITY

- FUTURE PRODUCTION ONLY
- RETROFIT UNITS IN PRODUCTION AND INVENTORY
- RETROFIT UNITS IN FIELD
- DRAWING CORRECTION ONLY; HARDWARE NOT AFFECTED
- _____

WRITTEN BY

DATE

DSO

1-4-82

APPROVED BY

DATE

DSO

1-4-82

OBERHEIM ELECTRONICS, INC.
ENGINEERING CHANGE ORDER

ECO NO.
202

PRODUCT AFFECTED

DSX

DRAWINGS AFFECTED

SCHEMATIC

PARTS LIST

DESCRIPTION OF CHANGE

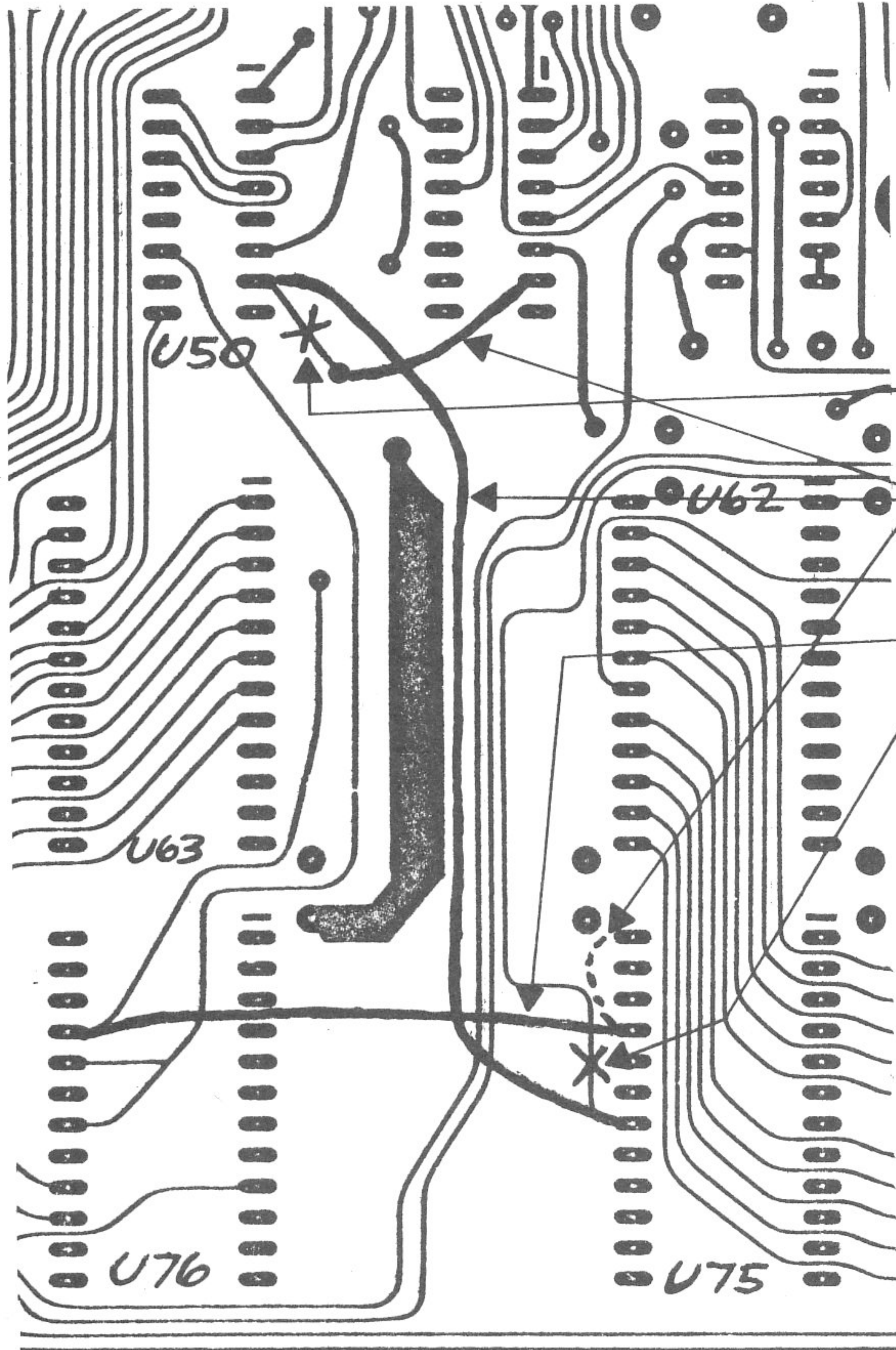

1. REMOVE DSX PROCESSOR BOARD BY DISCONNECTING CONNECTORS A THROUGH E AND UNSCREWING THE TEN SCREWS.
2. REMOVE JUMPER BETWEEN U75 PIN 24 AND U75 PIN 21 ON BACK OF BOARD.
3. CUT TRACE BETWEEN U75 PIN 18 AND U46 PIN 9 ON BACK OF BOARD.
4. CUT TRACE BETWEEN U50 PIN 7 AND FIRST FEED-THROUGH ON BACK OF BOARD.
5. ADD JUMPER BETWEEN U50 PIN 7 AND U75 PIN 18 ON BACK OF BOARD.
6. ADD JUMPER BETWEEN U75 PIN 21 AND U76 PIN 21 ON BACK OF BOARD.
7. ADD JUMPER BETWEEN U49 PIN 7 AND FEED-THROUGH ON BACK OF BOARD.
8. PLACE BOARD BACK IN CHASSIS AND RECONNECT ALL CONNECTORS AND SCREWS.
9. REPLACE E-PROMS:
E-PROM 'CØ' GOES INTO U76
E-PROM 'C1' GOES INTO U63
E-PROM 'C2' GOES INTO U75

BACK OF PROCESSOR BOARD -

REASON FOR CHANGE

TO ALLOW FOR EXTRA STORAGE OF NEW SOFTWARE BY CHANGING U75 FROM A 2716 E-PROM TO A 2732 E-PROM.

EFFECTIVITY

- FUTURE PRODUCTION ONLY
- RETROFIT UNITS IN PRODUCTION AND INVENTORY
- RETROFIT UNITS IN FIELD
- DRAWING CORRECTION ONLY; HARDWARE NOT AFFECTED
- _____

WRITTEN BY

DATE

John B. C. 2/10/82

APPROVED BY

DATE

J. B. C. 2/10/82

PRODUCT AFFECTED

DSX

DRAWINGS AFFECTED

SCHEMATIC
PARTS LAYOUT
PARTS LIST

DESCRIPTION OF CHANGE

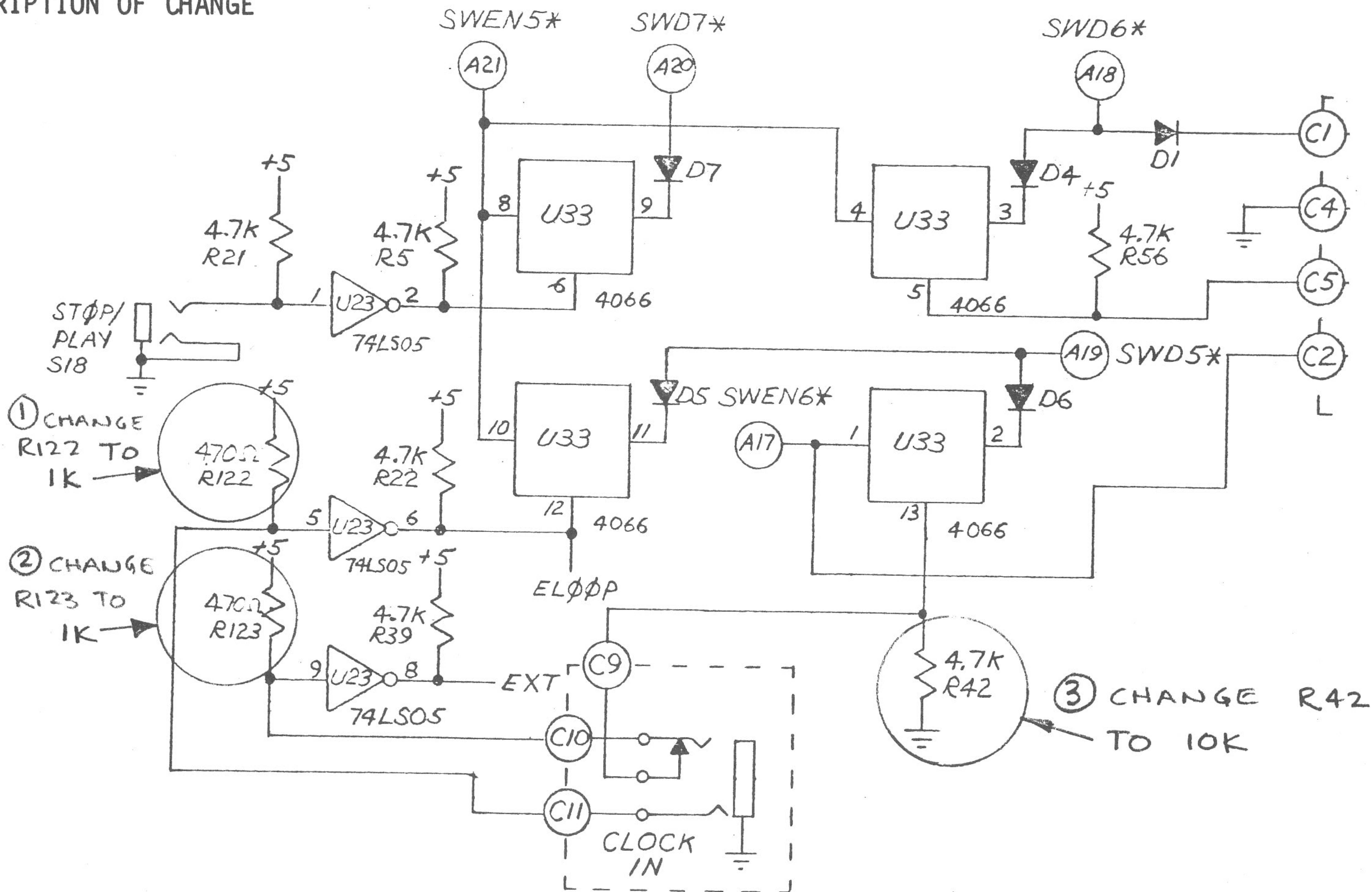

REASON FOR CHANGE

TO REDUCE CLOCK NOISE WHEN DSX IS SLAVED TO DMX

EFFECTIVITY

- FUTURE PRODUCTION ONLY
- RETROFIT UNITS IN PRODUCTION AND INVENTORY
- RETROFIT UNITS IN FIELD
- DRAWING CORRECTION ONLY; HARDWARE NOT AFFECTED

WRITTEN BY

DATE

M. B. G. 2/15/82

APPROVED BY

DATE

D. G. O. 2/15/82